

**TOWN OF BOWDOINHAM
PLANNING BOARD APPLICATION
SITE PLAN REVIEW**

**Town Office Renovations
13 School Street
Bowdoinham, Maine**

prepared for:

Town of Bowdoinham
13 School Street
Bowdoinham, Maine 04008
(207) 666-5531

prepared by:

Pine Tree Engineering, Inc.
53 Front Street
Bath, Maine 04530
(207) 443-1508

**April 2022
Project No. 21014**

TABLE OF CONTENTS

Transmittal Letter
Application Form
Project Location Map
Tax Map
Abutters
Photographs

APPROVAL CRITERIA RESPONSES

<u>Item</u>	<u>Description</u>
1)	Vehicular Access
2)	Internal Vehicular Circulation
3)	Pedestrian Circulation
4)	Municipal Services
5)	Visual Impact
6)	Lighting
7)	Signage
8)	Buildings
9)	Landscaping
10)	Buffering
11)	Utilities
12)	Water Supply
13)	Sewage Disposal
14)	Fire Protection
15)	Capacity of Applicant
16)	Special Resources
17)	Environmental Impact
18)	Noise
19)	Compliance with Ordinances
20)	Town Plans & Vision Statements

APPENDIX

A	Title, Right, or Interest
B	Cost Estimate
C	Flood Map (FIRMette)

DRAWINGS

Sheet 1 of 7	Cover
Sheet 2 of 7	Existing Conditions Plan
Sheet 3 of 7	Demolition and Site Preparation Plan
Sheet 4 of 7	Proposed Site Plan
Sheet 5 of 7	Proposed Utility Plan
Sheet 6 of 7	Proposed Grading and Drainage Plan
Sheet 7 of 7	Details

Pine Tree Engineering, Inc.

53 Front Street
Bath, Maine 04530
(207) 443-1508
Fax (207) 442-7029
E-mail: pte@pte-maine.com

April 7, 2022

Ms. Jennifer Curtis, Director of Planning & Development
Town of Bowdoinham
13 School Street
Bowdoinham, Maine 04008

Subject: Planning Board Application (Site Plan Review) #21014
Town Office Renovations
Bowdoinham, Maine

Dear Jenn:

On behalf of Town of Bowdoinham, we have enclosed two copies of the Planning Board Application (Site Plan Review) for the proposed Town Office Renovations project, along with two (2) sets of full-size plans and nine (9) sets of 11"x17" plans.

The proposed project involves the renovation of the John C. Coombs Municipal Building and the reconstruction and expansion of the existing parking area, as well as associated paving on School Street.

Sincerely,

PINE TREE ENGINEERING, INC.



Jeremy Prue, P.E.
Project Manager

JRP/tls





Town of Bowdoinham

13 School St • Bowdoinham, ME 04008

Phone 666-5531 • Fax 666-5532

www.bowdoinham.com

PLANNING BOARD APPLICATION

Type of Application: Shoreland Zoning Site Plan Review – Tier II Tier II
 Land Use Subdivision – Minor Major

Applicant Information:

Name: Town of Bowdoinham
Mailing Address: 13 School Street, Bowdoinham, Maine 04008
Telephone: (207) 666-5531
Right, Title, Interest in Property: Owner Other _____
(appropriate documentation must be provided)

Owner Information:

Same as Above
Name: _____
Mailing Address: _____
Telephone: _____

Agent Information:

Name: Pine Tree Engineering, Inc. — Jeremy Prue, P.E.
Mailing Address: 53 Front Street, Bath, Maine 04530
Telephone: (207) 443-1508
 Surveyor Engineer Other: _____

Property Information:

Map/Lot Number: U01-019 & U01-020
Property Address: 13 School Street
Lot Size: 1.40 acres Lot Frontage: 180.94'
Existing Lot Coverage: 45% Proposed Lot Coverage: 52%
Water Service: Public Private Road Ownership: State Town Private
Floodplain: No Yes Shoreland Zoning: No Yes: _____
Tax Program: No Agriculture Open Space Tree Growth

Project Description:

The proposed project involves the renovation of the John C. Coombs Municipal Building and the reconstruction and expansion of the existing parking area. Additionally, utility work will be completed including a new sprinkler service for the Town Office, new septic tanks, and new underground electric services. The proposed development will take place in the upland area and avoid impact to any wetlands.

Attachments (the following items are required):

- Site Plan
- Photographs of Site
- Application Fee (Not Applicable)
- Supporting Documents as required per Land Use Ordinance**

By signing this application, as the foresaid applicant:

- I certify that I have read and completely understand the application;
- I certify that the information contained in this application and it's attachments are true and correct;
- I understand that all information provided on this form and all other documents submitted as part of my proposal is a matter of public record;
- I understand that copies of this information may be supplied upon request to an interested party;
- I understand that additional funds may be required through the course of review for special studies, legal review costs, and/or engineering review;
- I understand that it is my responsibility to know and pay for any tax penalty that may result from said project;
- I understand that the information contained in this application is background information and some applications may require additional tests, maps, documentation or submissions as required by the Planning Board.

Applicant Signature Jeremy Proe Date 4/7/22

Print Name Jeremy Proe

FOR OFFICE USE ONLY



Received On: _____ Fee Paid: _____

Signed Date

PROJECT SITE

Bowdoinham, Maine

Legend

-  Bowdoinham Public Library
-  Bowdoinham Town Office

Bowdoinham Church of the Nazarene

School St

 Bowdoinham Public Library

 Bowdoinham Town Office

Stone Hill Pl

School St 100 ft



PROPERTY MAP
BOWDOINHAM
MAINE

2020
(As of April 1st)

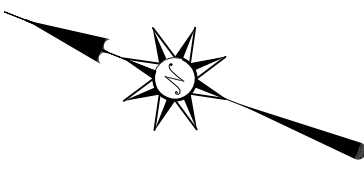

LEGEND	
ABUTTING MAP NO.	U01
PARCEL NUMBER	22
SUBDIVISION LOT NO.	④
LOT DIMENSION	156'
PROPERTY HOOKS	→ ←
RIGHT OF WAY	— — — —
EASEMENT	— — — —

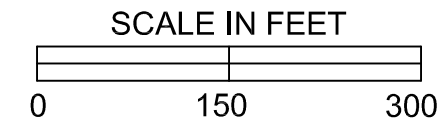

James H. Thomas
gisSolutions of Maine
Cumberland, Maine 04021
jht@maine.rr.com

U01

FOR ASSESSMENT PURPOSES ONLY
NOT FOR PROPERTY CONVEYANCES

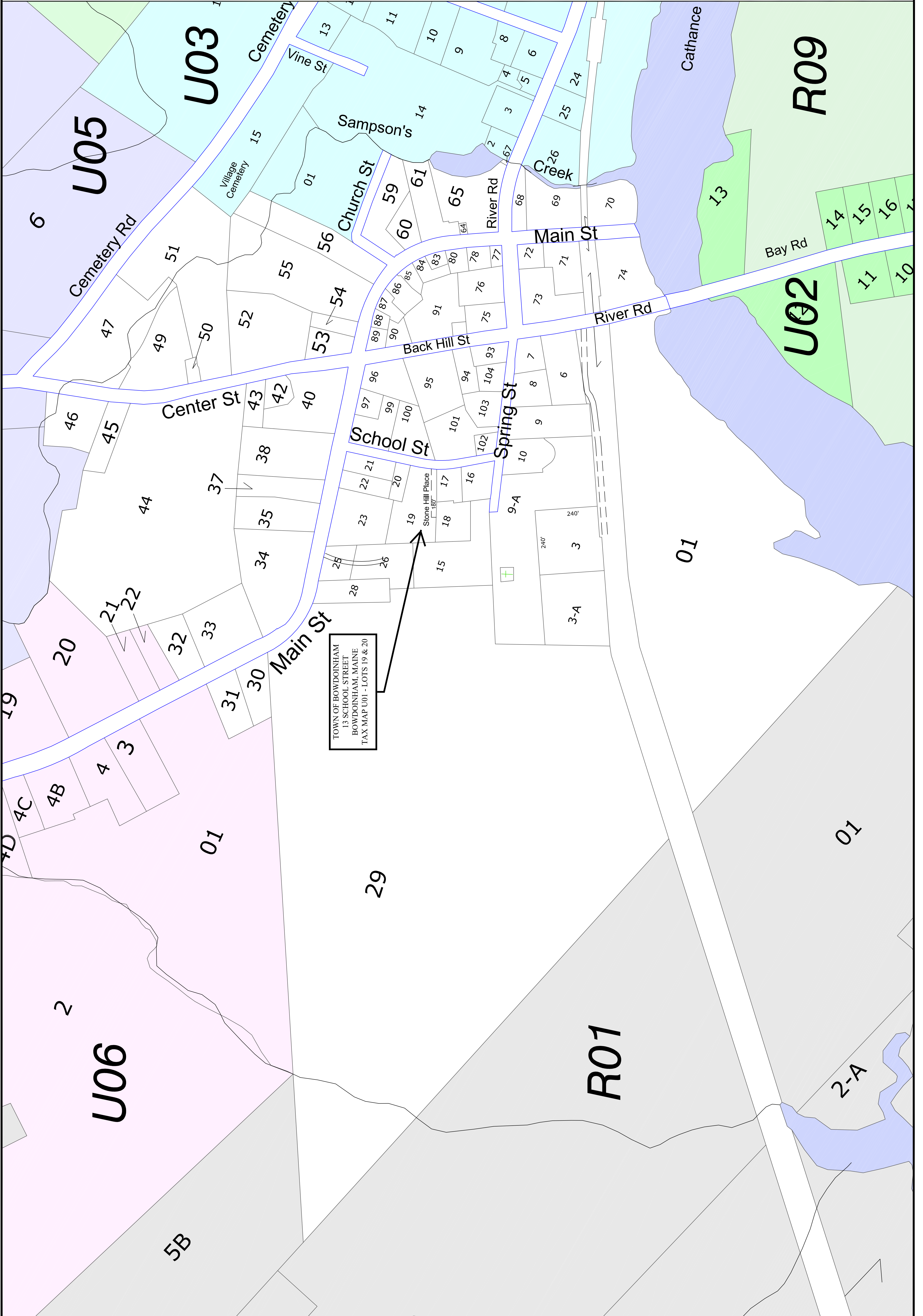

TOWN OF BOWDOINHAM
13 SCHOOL STREET
BOWDOINHAM, MAINE
TAX MAP U01 - LOTS 19 & 20

LIST OF ABUTTERS
Town Office Renovations
Bowdoinham, Maine

(within two hundred (200) feet of any and all property boundaries)

MAP/LOT	OWNER/MAILING ADDRESS
U01-15	Calvin W. & Jewel A. Temple 28 Spring Street Bowdoinham, Maine 04008
U01-16	Daniel B. & Kathleen A. Joyce 21 School Street Bowdoinham, Maine 04008
U01-17 & U01-18	Kathleen & Scott Gallant 8 Stone Hill Place Bowdoinham, Maine 04008
U01-21 & U01-22	First Church of the Nazarene 7 School Street Bowdoinham, Maine 04008
U01-23	Alyson Dame & Joshua Vermette 68 Main Street Bowdoinham, Maine 04008
U01-26	Jay E. Read P.O. Box 116 (74 Main Street) Bowdoinham, Maine 04008
U01-99	Frances Reis Jensen 56 Main Street Bowdoinham, Maine 04008
U01-100	Bradford P. & Jennifer I. Foley P.O. Box 256 (10 School Street) Bowdoinham, Maine 04008
U01-101	Sarah Ann Stapler P.O. Box 48 (16 School Street) Bowdoinham, Maine 04008
U01-102	Donald K. & Deborah A. Ludwig 17 Spring Street Bowdoinham, Maine 04008

PHOTOS FOR SITE PLAN REVIEW
BOWDOINHAM TOWN OFFICE



**APPROVAL CRITERIA RESPONSES
TOWN OFFICE RENOVATIONS
BOWDOINHAM, MAINE**

- 1) Vehicular Access – The proposed site layout will provide for safe access to and egress from public and private roads.
- 2) Internal Vehicular Circulation – The proposed site layout will provide for the safe movement of passenger, service, and emergency vehicles through the site.
- 3) Pedestrian Circulation – The proposed site layout will provide for safe pedestrian circulation both on-site and off-site.
- 4) Municipal Services – The development will not have an unreasonable adverse impact on municipal services, including municipal road systems, fire department, solid waste program, schools, open spaces, recreational programs and facilities, and other municipal services and facilities.
- 5) Visual Impact – The proposed development will not have an adverse effect on the scenic or natural beauty of the area, including water views and scenic views.
- 6) Lighting – All exterior lighting will be designed to avoid undue glare, adverse impact on neighboring properties and rights-of-ways, and the unnecessary lighting of the night sky.
- 7) Signage – The proposed signage will not detract from the design of the proposed development and the surrounding properties and will not constitute hazards to vehicles and pedestrians.
- 8) Buildings – The proposed structures will relate harmoniously to the terrain and to existing buildings in the vicinity, so as to have a minimally adverse effect on the environmental and aesthetic qualities of the neighboring areas.
- 9) Landscaping – The proposed development will maintain adequate landscaping in order to define, soften, and/or screen the appearance of parking and developed areas as well as to enhance the physical design of the buildings and the overall development.
- 10) Buffering – The proposed development will provide for the buffering of adjacent uses where there is a transition from one type of use to another use and for the screening of mechanical equipment and service and storage areas
- 11) Utilities – The proposed development will not impose an unreasonable burden on existing utilities.
- 12) Water Supply – The proposed development will be provided with an adequate supply of water.
- 13) Sewage Disposal – The proposed development will be provided with adequate sewage waste disposal.
- 14) Fire Protection – The proposed development will have adequate fire protection.

- 15) Capacity of Applicant – The applicant has the capacity to carry out the proposed project.
- 16) Special Resources –
 - a) Shoreland – The proposed development is not in the Shoreland Zone.
 - b) Floodplain – The proposed development is not in the Floodplain.
 - c) Wetlands & Waterbodies – The proposed development will not impact wetland or waterbodies.
 - d) Historic & Archaeological – The proposed development will not have an adverse effect on historic and/or archaeological sites.
 - e) Groundwater – The proposed development will not adversely impact either the quality or quantity of groundwater available to abutting properties or to public water supply systems.
 - f) Wildlife Habitat – The proposed development will not have an undue adverse effect on wildlife habitat.
 - g) Natural Areas – The proposed development will not have an undue adverse effect on rare and irreplaceable natural areas.
- 17) Environmental Impact – The landscape will be preserved in its natural state to the extent that is practical by minimizing tree removal, disturbance of soil and retaining existing vegetation.
 - a) Solid Waste Management – The proposed development will provide for adequate disposal of solid wastes.
 - b) Hazardous, Special & Radioactive Materials – The proposed development will handle, store, and use all materials identified as hazardous, special or radioactive in accordance with the standards of Federal and State agencies.
 - c) Air Quality – The proposed development will not result in undue air pollution or odors.
 - d) Water Quality – The proposed development will not result in water pollution.
 - e) Stormwater – The proposed development will provide for the collection and disposal of all stormwater that runs off proposed streets, parking areas, roofs, and other impervious surfaces, which must not have an adverse impact on abutting or downstream properties.
 - f) Sedimentation & Erosion Control – The proposed development will take adequate measures to prevent soil erosion and the sedimentation of watercourses and waterbodies.
- 18) Noise – The proposed development will control noise levels so that it will not create a nuisance for neighboring properties.
- 19) Compliance with Ordinances – The proposed development conforms with the provisions of this Land Use Ordinance and other ordinances and regulations of the Town of Bowdoinham.
- 20) Town Plans & Vision Statements – The proposed development is consistent with the intent of the Town’s Plans, including but not limited to the Comprehensive Plan, Waterfront Plan, and Transportation Vision Statement.

APPENDIX A

Title, Right, or Interest

Quitclaim,
 Milloy & al.
 to
 Bowdoinham

Know all men by these presents that we the subscribers, Jew owners and proprietors of the Universalist Meeting house formerly called the Union Meetinghouse in Bowdoinham in the county of Sagadahoc in consideration of one dollar to us paid by the inhabitants of the town of Bowdoinham, the receipt whereof is hereby acknowledged, do hereby convey, remise, release and forever quitclaim unto the said inhabitants of the town of Bowdoinham the following described lot of land with the building thereon, situated

in Bowdoinham village in the said county of Sagadahoc and bounded and described as follows, to wit, commencing at a stone post set in ground on the western side of land in possession of Bonnerse Purington & on the Eastern side of way leading by the front of the said Meeting house, thence running to the South East corner of land in possession of Thomas J. Crocker; thence to a right-of way between school house and said Meeting house; thence by said right of way to the way leading by the front of said Meeting house, thence by said way to the first-mentioned bound with all the privileges and appurtenances thereto belonging. Meaning to convey by this deed the Universalist-Meeting-house and the original lot of land upon which the said Universalist-Meeting-house is situated. Reserving the right power and permission to the said pew owners and proprietors, their heirs and assigns and the Universalist society of Bowdoinham to use and occupy the above described premises with the buildings thereon for all coming time for religious purposes and meetings free from rental, when not occupied by said inhabitants for elections, election purposes and town meetings. Also reserving to all other religious societies in the town of Bowdoinham the right to occupy the above premises for all coming time free of rental when the same is not occupied by the said inhabitants, pew owners and proprietors and Universalist society - Said societies to pay for warming, lighting and services of janitor for taking care of said building, whenever they oc-

copy the same. Said journey always to be employed by said inhabitants, whose duty shall be to take care of said building on all occasions & for all purposes.

To have and to hold the above released premises to the said inhabitants to their use and behoof forever. And we the said few owners and proprietors for ourselves, our heirs, executors and administrators do covenant with the said inhabitants that the premises are free from all incumbrances made or suffered by us and that we will and our heirs, executors and administrators shall warrant and defend the same to the said inhabitants forever against the lawful claims and demands of all persons, claiming by, through or under us but against none other.

In witness whereof we the said few owners and proprietors have hereunto set our hands and seals this seventh day of February A. D. 1883.

Signed, sealed and delivered

in presence of

Edward J. Milloy.

John L. Patten.

P. K. Milloy. Seal.

H. D. Sampson. Seal.

Barrett Thorn. Seal.

George Curtis. Seal.

M. H. Bibber. Seal.

James Graves. Seal.

Rufus Small. Seal.

Susan J. Maloon. Seal.

Eliza Vaney. Seal.

James K. Milloy. Seal.

John Milloy. Seal.

Kate J. Graves. Seal.

R. J. Milloy. Seal.

Thomas Tyler. Seal.

John Harward. Seal.
 Reuben Blake. Seal.
 James Sampson. Seal.
 Geo. F. Lincker. Seal.
 E. A. Gray. Seal.
 Margaret Davis. Seal.
 Arabine P. Hall. Seal.
 Geo. B. Sampson. Seal.
 Ann M. Thompson. Seal.
 Mary G. Sampson. Seal.
 John H. Millay. Seal.
 E. J. Millay. Seal.

State of Maine, Sagadahoc Co. Feb. 7, A. D. 1883.
 Personally appeared the within named
 grantors and acknowledged the within
 instrument by them subscribed to
 be their free act and deed.

Before Me,

Edward J. Millay, Justice of the Peace.

State of Maine, Sagadahoc Co. March 5th 1883.

Then personally appeared Edward J. Millay
 one of the within grantors and acknowl-
 edged the within instrument to be his
 free act & deed. Before Me,

John L. Patten Justice of the Peace.

Received February 4, 1884 at 12 h. 15 m.
 P. M., and recorded from the original.

Attest: George W. Hunt Register.

DISTRICT COURT
WEST BATH
DOCKET NO.: RE-18-008

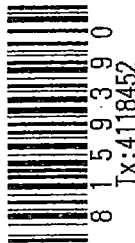

STATE OF MAINE
SAGADAHOC, ss.

TOWN OF BOWDOINHAM,)

Plaintiff)

v.)

ELLA S. HIGGINS, believed)
deceased,)
her heirs,)
legal representatives,)
devisees, assigns,)
trustees in bankruptcy,)
disseizors,)
creditors, lienors, and)
grantees and any and all persons)
unascertained or not, in being or)
unknow or out of state, and all other)
persons whomsoever)
who may claim any right, title,)
interest or estate, legal or equitable,)
in the within described land and)
real estate through or under said)
ELLA S. HIGGINS,)
Defendants)

DEFAULT JUDGMENT
(Title to Real Estate Involved)

INTRODUCTION

Plaintiffs in this action seek a declaratory judgment and to quiet title to property located off of School Street in Bowdoinham, Maine (the "Property") described as follows:

A certain lot or parcel of land situated in the Village of said Bowdoinham, with the buildings thereon and bounded and described as follows, to wit: Northerly by the land of Ella L. Staples; Easterly by the Town House Lot, so-called; Southerly by the School House Lot, so-called; Westerly by land of Ella L. Staples. Containing one fourth acre of land more or less.

A True Copy Attest:

Antia Alexander
Clerk

DISCUSSION

As a result of a break in the chain of title, the Heirs of Ella S. Higgins may have an interest in a portion of the Property, which Plaintiffs have been occupying since at least 1986. To resolve this ambiguity, Plaintiff commenced this action to quiet and establish Plaintiff's title by way of adverse possession.

Following the preparation of a professional genealogical research report and its presentation to this court, it was determined that the exact identity of Defendants was not readily identifiable, and that no current mailing addresses for said Defendants, were available. Upon petition to this court, Plaintiffs were permitted to complete service on Defendants by publication in the *Times Record*, a newspaper of general circulation in and around the location of the Property. Each of the defendants have been served in accordance with the Maine Rules of Civil Procedure, following said publication. Following completion of service, all defendants have been defaulted by the Clerk, because all have failed to file a responsive pleading.

JUDGMENT

Accordingly, this entry shall be:

Title to the Property in fee simple absolute is confirmed in the name of the Town of Bowdoinham. Any interest that any of the above-named Defendants may have had in the Property is hereby extinguished and stopped as a result of their failure to file a responsive pleading in this matter.

Plaintiffs shall be responsible for recording fees for this judgment in the Sagadahoc County Registry of Deeds.

The Clerk shall incorporate this Judgment on the docket, pursuant to Rule 79(a).

Dated: _____

7/10/18

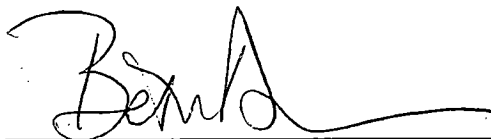

Judge, District Court

A True Copy Attest:

Clerk

CLERK'S CERTIFICATION

I, Erin Reed, Clerk of the West Bath District Court, hereby certify that:

On 8-1-18, 2018, any applicable appeal period in this case expired without action.

OR

On _____, 2018, within the time limits imposed by the Maine Rules of Civil Procedure and Maine Statutes, an appeal was filed by _____

A True Copy Attest:

DATE: 8-8-18

ATTEST:

Antia Alexander
Clerk

Erin Reed
Asst. Clerk, West Bath District Court

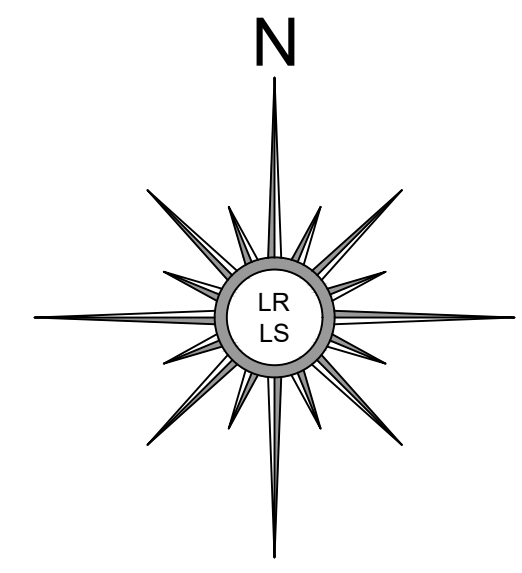
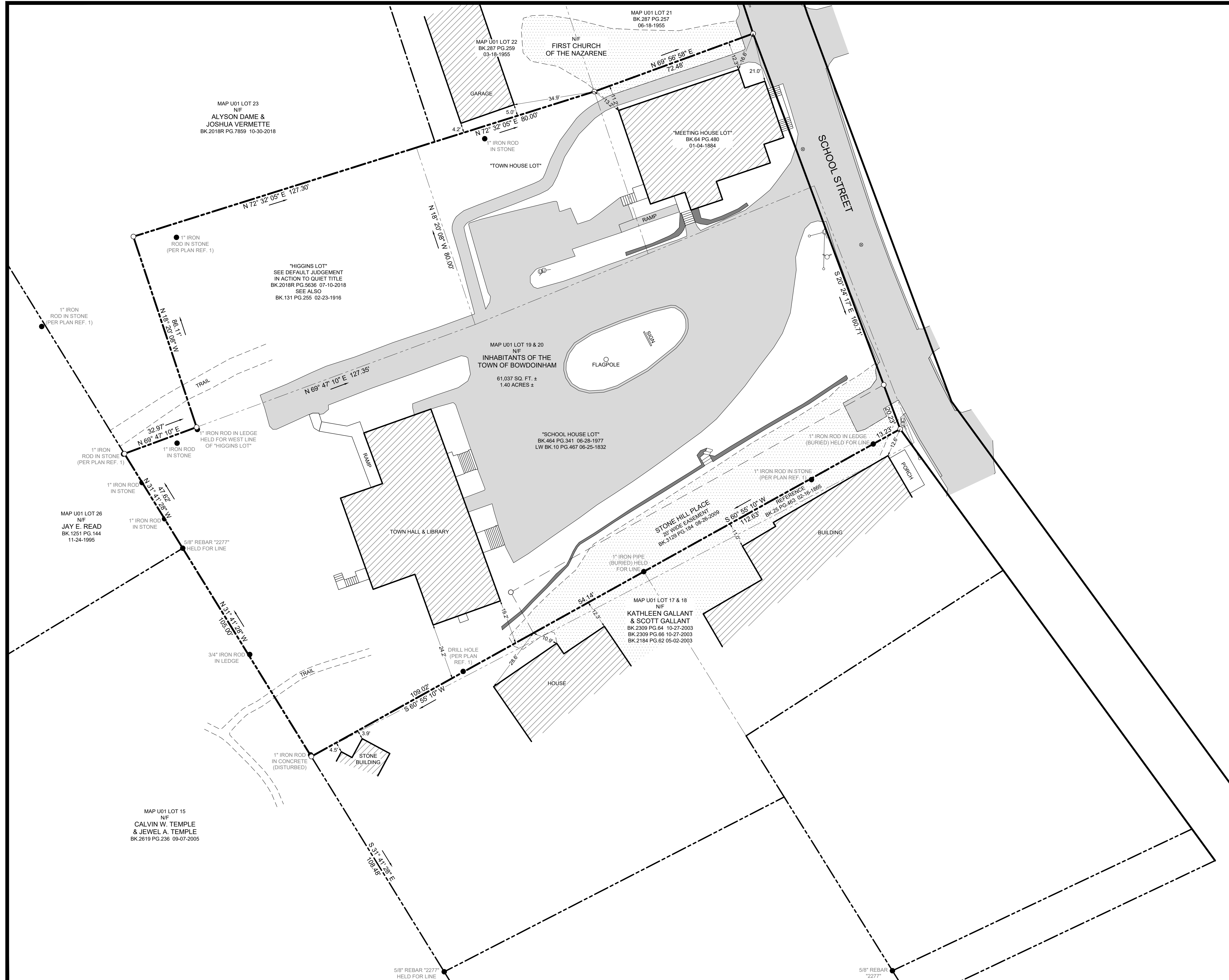

SOURCE
SPCS - 1983 MAINE WEST

LEGEND

- PIPE OR ROD FOUND
- 5/8" REBAR SET CAPPED "2376"
- RIGHT OF WAY
- PROPERTY LINE
- - - BUTTERS LINE
- - - HISTORICAL LINE
- - - EASEMENT LINE
- ▨ BUILDING
- ▨ ASPHALT
- ▨ GRAVEL
- ▨ RETAINING WALL
- ⊗ WATER VALVE
- ⊕ HYDRANT
- ⊕ - ⊕ UTILITY POLE AND ANCHOR

GENERAL NOTES

- 1) RECORD OWNERS: INHABITANTS OF THE TOWN OF BOWDOINHAM
SEE DEED BOOK 464, PAGE 341 DATED JUNE 26, 1977
SEE DEED BOOK 64, PAGE 480 DATED JANUARY 4, 1984
SEE LINCOLN COUNTY WEST DEED BOOK 10, PAGE 467 DATED JUNE 25, 1832
SEE JUDGEMENT IN ACTION TO QUIET BOOK 2018R PAGE 5636 DATED JULY 10, 2018
BOUNDARIES SHOWN HEREON ARE BASED ON MONUMENTATION FOUND AND PROPERTY LINES SHOWN ON PLAN REFERENCES 1 AND 2. THIS SURVEYOR HAS REVIEWED THE VARIOUS HISTORICAL DEEDS CITED THEREON AND AGREES WITH THE OPINION OF THE SURVEYORS WHO PRODUCED SAID PLANS. ALL BOOK AND PAGE NUMBERS ARE TO THE SAGADAHOC COUNTY REGISTRY OF DEEDS UNLESS OTHERWISE NOTED.
- 2) BEARINGS ARE REFERENCED TO THE STATE PLANE COORDINATE SYSTEM OF 1983, MAINE WEST ZONE, AS DETERMINED BY STATIC GNSS OBSERVATION WITH POST PROCESSING BY THE NATIONAL GEODETIC SURVEY ONLINE POSITIONING USER SERVICE.

PLAN REFERENCES

- 1) "STANDARD BOUNDARY SURVEY SCHOOL STREET, BOWDOINHAM" DATED OCTOBER 1, 1997 AND RECORDED IN PLAN BOOK 2015P, PAGE 10.
- 2) "BOUNDARY SURVEY OF THE CALVIN & JEWEL TEMPLE LOTS" DATED MARCH 4, 2015 AND RECORDED IN PLAN BOOK 2015P, PAGE 25.

CERTIFICATION

TO: THE INHABITANTS OF THE TOWN OF BOWDOINHAM
TO THE BEST OF MY KNOWLEDGE THIS SURVEY CONFORMS TO THE MAINE BOARD OF LICENSURE FOR LAND SURVEYORS STANDARDS WITH THE FOLLOWING EXCEPTIONS:
1) NO SEPARATE REPORT

Jeremiah J. Raitt
JERAMIAH J. RAITT PLS #2376
STATE OF MAINE
JERAMIAH RAITT
No. 2376
PROFESSIONAL
LAND SURVEYOR

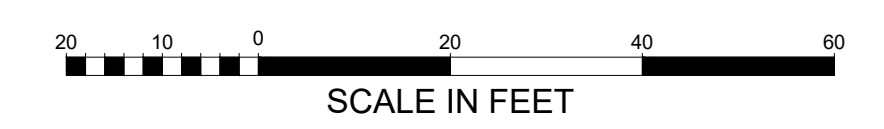

RETRACEMENT SURVEY	
RECORD OWNER INHABITANTS OF THE TOWN OF BOWDOINHAM 13 SCHOOL STREET, BOWDOINHAM, MAINE 04008	
SITE 13 SCHOOL STREET BOWDOINHAM, MAINE	
LITTLE RIVER LAND SURVEYING, INC. ME PLS 2376 NH LLS 957 MA LS 56221 PO BOX 332, LISBON FALLS MAINE 04252 (207) 841-0056	DATE: FEB. 17, 2022 REVISED: MARCH 16, 2022 SCALE: 1" = 20' PROJECT: 21-131 DRAWING: 21-131 DRAWN BY: TJC CHECKED BY: JUR

After recording return to:
Lawrence C. Walden, Esq.
Bergen & Parkinson, LLC
62 Portland Road, Suite 25
Kennebunk, ME 04043

Space Above This Line For Recording

EASEMENT

KNOW ALL MEN BY THESE PRESENTS, THAT, the **INHABITANTS OF THE TOWN OF BOWDOINHAM**, a municipal corporation, located in Bowdoinham, in the County of Sagadahoc, and State of Maine, in consideration of One Dollar and other good and valuable consideration paid by **KATHLEEN GALLANT**, of Bowdoinham, in the County of Sagadahoc, and State of Maine, the receipt of which is hereby acknowledged, and whose mailing address is 17 School Street, Bowdoinham, Maine, 04008, do hereby release, bargain, sell and convey, unto the said **KATHLEEN GALLANT**, her heirs and assigns forever, the following described easement:

A perpetual easement over and across a portion of the Grantor's property on the westerly side of School Street, in Bowdoinham, Sagadahoc County, Maine, being a strip of land twenty (20) feet in width running from School Street, and along the southerly boundary of the School House Lot, acquired by the Town of Bowdoinham, by virtue of Deed from School Administrative District #75, dated June 28, 1977, and recorded in the Sagadahoc County Registry of Deeds in Book 464, Page 341; said easement running in a generally westerly direction from School Street along said boundary line for a distance of one hundred and eighty (180) feet. The boundary line is as more particularly shown on the Survey of the School Street Municipal Lots for the Town of Bowdoinham, by Harty & Harty Professional Land Surveying, dated October 1, 1997, as running from a point on School Street South Seventy-Seven Degrees, Thirty-Seven Minutes, Fifty-Two Seconds West (S 77° 37' 52" W).

This easement is for the purpose of constructing, establishing, and maintaining a driveway to be used as access from School Street to premises of this Grantee which property is more particularly described in the deed from Patrick P. Haggerty to Kathleen Gallant, then known as Kathleen Haggerty, dated April 26, 1996, and recorded in the Sagadahoc County Registry of Deeds in Book 1419, Page 16, and premises acquired by Kathleen Gallant by Deed from Dianna J. Thibodeau, dated July 12, 2002, and recorded in the Sagadahoc County Registry of Deeds in Book 2028, Page 124. This driveway easement is exclusively for driveway purposes, and the maintenance of the driveway shall be conducted in a manner that will cause the driveway to be serviceable and will not interfere with or endanger the use of other adjacent Town owned property. All expenses for establishment, construction and maintenance of the driveway shall be at the sole expense of the Grantee. The Grantee's use of Grantor's property shall be limited to the driveway area described above and shall not encroach upon or otherwise interfere with the Town's use of its remaining property.

As consideration for this easement, the Grantee herein, her heirs and assigns, do hereby covenant with the Town of Bowdoinham to refrain from erecting any buildings or structures, or adding on to any existing building or structure on Grantee's property that would impair, impede or otherwise block or diminish the view or 'view shed' from the Town Office building looking southerly and southwesterly across Grantee's property. The purpose of this covenant and condition is to maintain the current view or view shed as presently enjoyed by the Town Office building and to prevent the view or view shed from being diminished any time in the future.

As additional consideration for this easement, the Grantee shall defend and shall indemnify and hold harmless Grantor, its members, officers and employees, from and against all claims, causes of action, suits, losses, damages and expenses, including attorney's fees, arising out of or resulting from use of this easement by Grantee or her successors, assigns, invitees, agents, family or others; or from negligent acts, errors or omissions by Grantee, or her successors, assigns, invitees, agents, family or others or breach of duties to Grantor by Grantee, or her successors, assigns, invitees, agents, family or others in use of this Easement. Such obligation shall not be construed to negate or abridge any other obligation of indemnification running to Grantor, which would otherwise exist. Grantor shall give Grantee prompt and timely notice of any claims, threatened or made, or suit instituted against it, which could result in a claim for indemnification, hereunder, provided, however, that lack of such notice shall not be a waiver of Grantee's indemnification of Grantor. Grantor shall cooperate with Grantee in the defense of such a claim.

TO HAVE AND TO HOLD, the same, together with all the privileges and appurtenances thereunto belonging, to the said KATHLEEN GALLANT, her heirs and assigns.

IN WITNESS WHEREOF, the INHABITANTS OF THE TOWN OF BOWDOINHAM has caused this instrument to be signed in its corporate name and sealed with its corporate seal by its Selectmen, thereunto duly authorized this 26 day of August, 2009.

SIGNED, SEALED AND DELIVERED
IN PRESENCE OF

INHABITANTS OF THE TOWN OF
BOWDOINHAM
By: Its Selectmen



DAVID WHITTLESEY, Chair



STEVEN CIEMBRONIEWICZ

Brian Hobart

BRIAN HOBART

STATE OF MAINE
SAGADAHOC, SS,

August 26, 2009

Personally appeared the above named DAVID WHITTLESEY, STEVEN CIEMBRONIEWICZ, and BRIAN HOBART, the Selectmen of the Town of Bowdoinham, and acknowledged the above instrument to be their free act and deed in their said capacity and the free act and deed of the said municipality.

Before me,

Kathryn Durgin Leighton

Notary Public/Attorney At Law

Typed or Printed Name Kathryn Durgin-Leighton

My Commission Expires: June 25, 2012

KATHRYN DURGIN-LEIGHTON
Notary Public, Maine
My Commission Expires June 25, 2012



*** NOT A TRUE COPY NOT A TRUE COPY NOT A TRUE COPY ***

SAGADAHOC COUNTY

Barbara J. Trott

Register of Deeds

Know all Men by these Presents

That SCHOOL ADMINISTRATIVE DISTRICT NO. 75, a body corporate and politic, located at Topsham, in the County of Sagadahoc and State of Maine,

~~XX~~

~~XX~~

~~XX~~

~~XX~~

in consideration of One dollar and other good and valuable considerations,

paid by THE INHABITANTS OF THE TOWN OF BOWDOINHAM, a municipal corporation existing by law in the County of Sagadahoc and State of Maine,

the receipt whereof it does hereby acknowledge, does hereby

give, grant, bargain, sell and convey unto the said THE INHABITANTS OF THE TOWN OF BOWDOINHAM, its successors,

owns and assigns forever,

PARCEL 1.

a certain lot or parcel of land situated in Bowdoinham aforesaid bounded as follows, to wit:

Commencing one rod and two links from the southeast corner of the Main body of the Village Meeting House in the south line of said Meeting House lot on a course from said southeast corner south 8-1/2 degrees east seven rods and four links to stake and stones; thence south 75-1/2 degrees west to land owned by Job Gray thence northerly by said Job Gray's land to land deeded by us to Henry and Loring Fisher and from thence easterly by said Fisher's land Town House lot and Meeting House lot to the first mentioned bounds being the same lot where the School House now stands.

Reference may be made to Warranty Deed from Samuel Gray and Benjamin Stinson to the Inhabitants of the ninth School District in Bowdoinham dated May 25, 1832 and recorded in the Lincoln County West Registry of Deeds in Volume 10, Page 467.

Further reference may be had to a deed from the Grantees herein to the Grantors herein dated June 17, 1976 and recorded in the Sagadahoc County Registry of Deeds.

PARCEL 2.

A certain lot or parcel of land, with the buildings thereon, situated in Bowdoinham in said County of Sagadahoc and bounded and described as follows: A certain lot or parcel of land (with all buildings thereon) buildings have been burned situated in said Bowdoinham in the village thereof, and bounded and described as follows, to wit:

Northerly by land of Ella L. Staples Heirs; easterly by the Town Hall lot, so-called westerly by land of Ella L. Staples Heirs; southerly by the School House lot, so-called, containing one-fourth of an acre more or less. Meaning to convey the same premises as conveyed to me by Warranty Deed from Anna Beals Malier April 8, 1925 and recorded in Sagadahoc County Registry of Deeds, Book 158, Page 464. Also being the same property as deeded to Anna Beals Malier by Warranty Deed from Ruth A. Jacques, and recorded in Book 155, Page 325, September 11, 1923. To all of said records, reference may be had for further description. Said sale of land by me to said Inhabitants of Bowdoinham is in accordance with vote of the Town to purchase, vote being taken at the Annual meeting March 4, 1935.

Further reference may be had to a deed from the Grantees herein to the Grantors herein dated June 17, 1976 and recorded in the Sagadahoc County Registry of Deeds

*** NOT A TRUE COPY ***

164 PAGE 342
To Have and to Hold the aforesaid and bargained premises with all the privileges and appurtenances thereof to the said THE INHABITANTS OF THE TOWN OF BOWDOINHAM, its successors

and assigns, to it and ~~their~~ use and behoof forever.

And does COVENANT with the said Grantee, its successors and assigns, that it is lawfully seized in fee of the premises that they are free of all encumbrances:

that it has ~~now~~ good right to sell and convey the same to the said Grantee to hold as aforesaid; and that it and its successors and assigns will WARRANT and DEFEND the same to the said Grantee, its successor and assigns forever, against the lawful claims and demands of all persons.

In Witness Whereof, the said SCHOOL ADMINISTRATIVE DISTRICT NO. 75 has caused this instrument to be sealed with its corporate seal and signed in its corporate name by Arthur Trusiani

Board of Directors, its Chairman, thereunto duly authorized, this twenty-eighth day of June in the year one thousand nine hundred and seventy-seven.

Signed, Sealed and Delivered in presence of

Ralph L. Ulmer

SCHOOL ADMINISTRATIVE DISTRICT 75

By *Arthur Trusiani* Its Chairman, Board of Directors

*** NOT A TRUE COPY ***

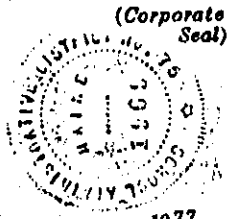

State of Maine, Sagadahoc

June 28, 1977

Then personally appeared the above named Ralph L. Ulmer and Arthur Trusiani of said Grantor Corporation as aforesaid, and acknowledged the foregoing instrument to be his free act and deed in his said capacity, and the free act and deed of said corporation.

Before me, Priscilla N. Hall

Justice of the Peace Notary Public PRISCILLA N. HALL NOTARY PUBLIC - MAINE MY COMMISSION EXPIRES OCT. 4, 1978

SAGAD. HOC, SS RECEIVED JUL 8 1977 9 11 05 M. A. H. AND RECORDED FROM THE ORIGINAL REGISTER

Janell W. Sloter

APPENDIX B

Cost Estimate

**Construction Cost Estimate
 Town Office Renovations Sitework
 Bowdoinham, Maine**

Item	Description	Quantity	Unit Price	Total
1.	Traffic Control	LUMP SUM	\$ 5,000	\$ 5,000
2.	Erosion & Sedimentation Control	LUMP SUM	5,000	5,000
3.	Clearing & Grubbing	LUMP SUM	5,000	5,000
4.	Common Excavation	1,475 CY	15	22,125
5.	6" Type A MaineDOT Base Course Gravel	400 CY	35	14,000
6.	12" Type B MaineDOT Base Course Gravel	50 CY	50	2,500
7.	12" Type D MaineDOT Subbase Course Gravel	800 CY	35	28,000
8.	HMA Surface Pavement 9.5 mm	220 TONS	135	29,700
9.	HMA Sidewalk Pavement 9.5 mm (handwork)	15 TONS	150	2,250
10.	HMA Base Pavement 19.0 mm	250 TONS	135	33,750
11.	HMA Trench Base Pavement 19.0 mm	40 TONS	150	6,000
12.	Subgrade Stabilization Geotextile	2,100 SY	3	6,300
13.	Slipform Concrete Curb	1,020 LF	10	10,200
14.	Reinforced Concrete Pads	LUMP SUM	4,000	4,000
15.	6' High Wooden Stockade Fence	140 LF	25	3,500
16.	Pavement Markings & Signs	LUMP SUM	10,000	10,000
17.	Loam, Seed & Mulch	LUMP SUM	5,000	5,000
18.	Septic Tank & Access Covers	2 EA	5,000	10,000
19.	6" DI Sprinkler Service & Tapping Sleeve and Valve	220 LF	50	11,000
20.	Electrical Trench Utility Excavation and Backfill	400 LF	10	4,000
21.	Drain Manhole	1 EA	3,000	3,000
22.	Catchbasin (4' Dia.)	6 EA	3,000	18,000
23.	12" HDPE Storm Drains	140 LF	50	7,000
24.	15" HDPE Storm Drains	510 LF	60	30,600
25.	4" PE Drain Pipe	65 LF	40	2,600
26.	Trench Rock Excavation (hammer)	20 CY	250	5,000
27.	Mobilization	LUMP SUM	10,000	10,000
			Subtotal:	\$ 293,525
			Contingency:	\$ 31,475
			Total:	\$ 325,000

Alternate Bid Item

28.	Remove & Reset Stone Retaining Wall	LUMP SUM	20,000	\$ 20,000
-----	-------------------------------------	----------	--------	-----------

**PINE TREE
 ENGINEERING**

APPENDIX C

Flood Map (FIRMette)

National Flood Hazard Layer FIRMMette



69°54'18"W 44°0'43"N



0 250 500 1,000 1,500 2,000 Feet 1:6,000

Basemap: USGS National Map: Orthoimagery: Data refreshed October, 2020

Legend

SEE FIS REPORT FOR DETAILED LEGEND AND INDEX MAP FOR FIRM PANEL LAYOUT

SPECIAL FLOOD HAZARD AREAS		Without Base Flood Elevation (BFE) <i>Zone A, V, A99</i>
		With BFE or Depth <i>Zone AE, AO, AH, VE, AR</i>
		Regulatory Floodway
OTHER AREAS OF FLOOD HAZARD		0.2% Annual Chance Flood Hazard, Areas of 1% annual chance flood with average depth less than one foot or with drainage areas of less than one square mile <i>Zone X</i>
		Future Conditions 1% Annual Chance Flood Hazard <i>Zone X</i>
		Area with Reduced Flood Risk due to Levee. See Notes. <i>Zone X</i>
		Area with Flood Risk due to Levee <i>Zone D</i>
OTHER AREAS		NO SCREEN Area of Minimal Flood Hazard <i>Zone X</i>
		Effective LOMRs
GENERAL STRUCTURES		Area of Undetermined Flood Hazard <i>Zone D</i>
		Channel, Culvert, or Storm Sewer
		Levee, Dike, or Floodwall
OTHER FEATURES		20.2 Cross Sections with 1% Annual Chance Water Surface Elevation
		17.5 Coastal Transect
		Base Flood Elevation Line (BFE)
		Limit of Study
		Jurisdiction Boundary
MAP PANELS		Coastal Transect Baseline
		Profile Baseline
		Hydrographic Feature
		Digital Data Available
		No Digital Data Available
		Unmapped
		The pin displayed on the map is an approximate point selected by the user and does not represent an authoritative property location.



This map complies with FEMA's standards for the use of digital flood maps if it is not void as described below. The basemap shown complies with FEMA's basemap accuracy standards

The flood hazard information is derived directly from the authoritative NFHL web services provided by FEMA. This map was exported on **3/16/2022 at 9:55 AM** and does not reflect changes or amendments subsequent to this date and time. The NFHL and effective information may change or become superseded by new data over time.

This map image is void if the one or more of the following map elements do not appear: basemap imagery, flood zone labels, legend, scale bar, map creation date, community identifiers, FIRM panel number, and FIRM effective date. Map images for unmapped and unmodernized areas cannot be used for regulatory purposes.

CONSTRUCTION DRAWINGS

TOWN OFFICE RENOVATIONS

SITework

TOWN OF BOWDOINHAM

PINE TREE ENGINEERING, INC.
53 Front Street
Bath, Maine 04530

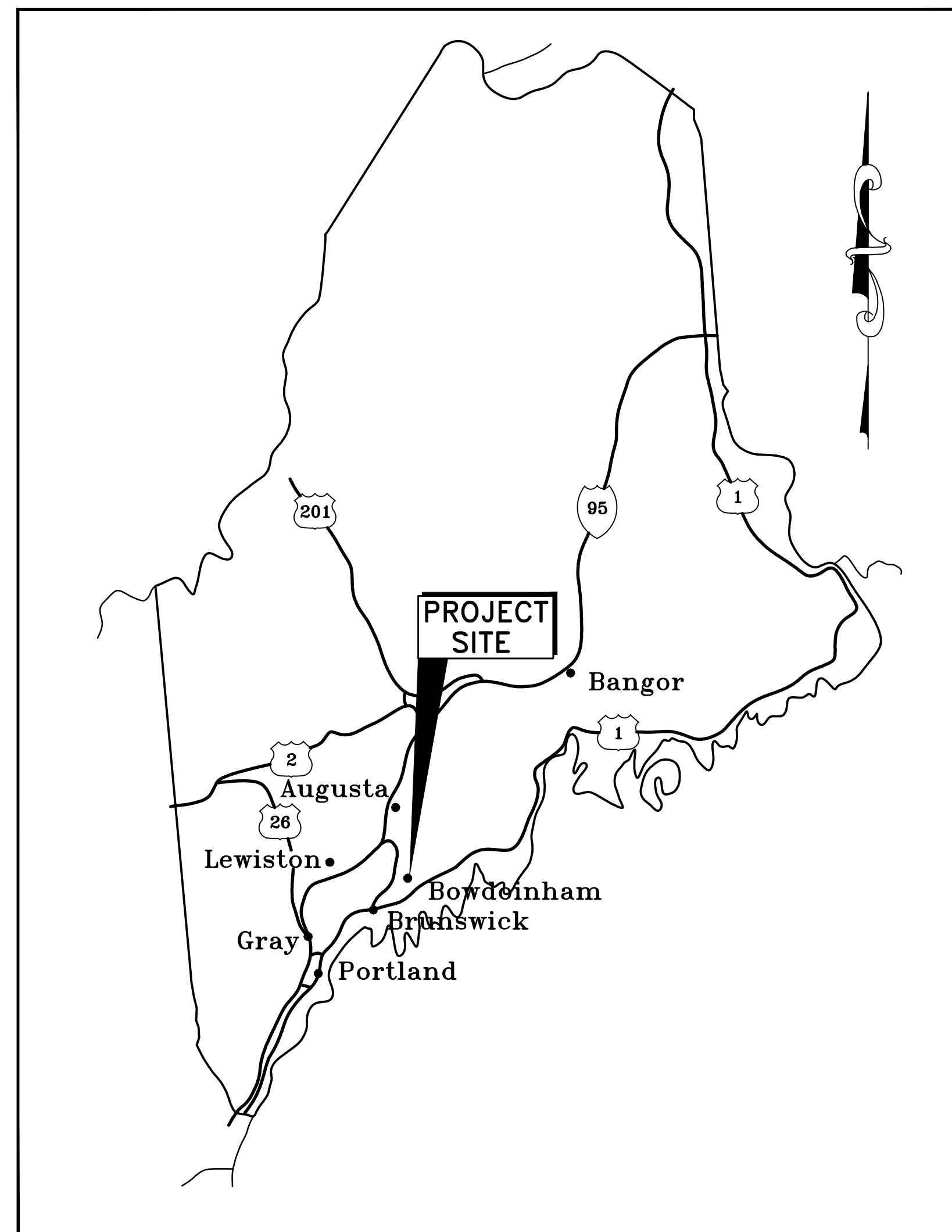

LOCATION MAP
SCALE: 1"=33± MILES

DRAWING INDEX

- 1 COVER
- 2 EXISTING CONDITIONS PLAN
- 3 DEMOLITION AND SITE PREPARATION PLAN
- 4 PROPOSED SITE PLAN
- 5 PROPOSED UTILITY PLAN
- 6 PROPOSED GRADING AND DRAINAGE PLAN
- 7 DETAILS

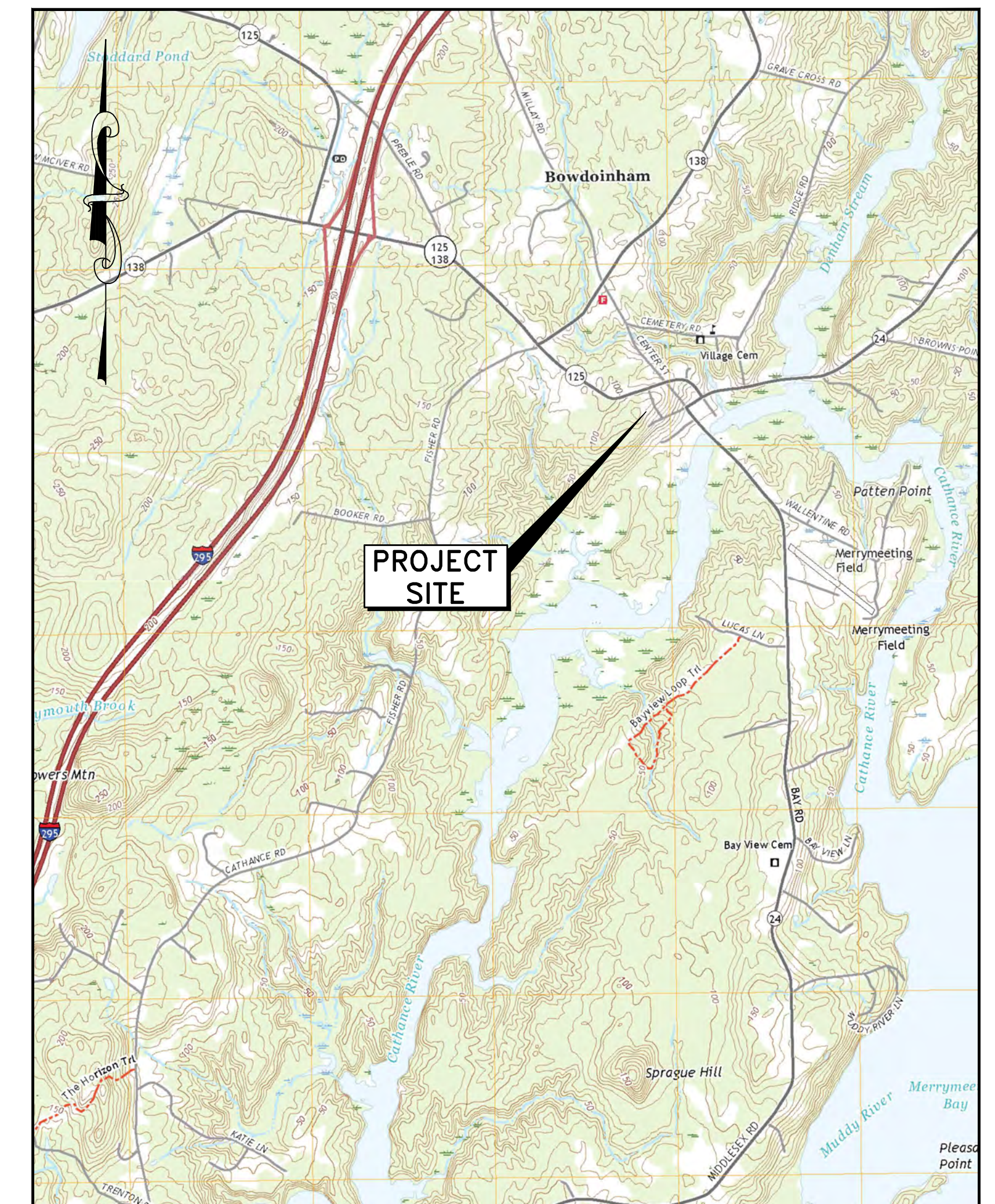

AREA MAP
SCALE: 1"=2000±

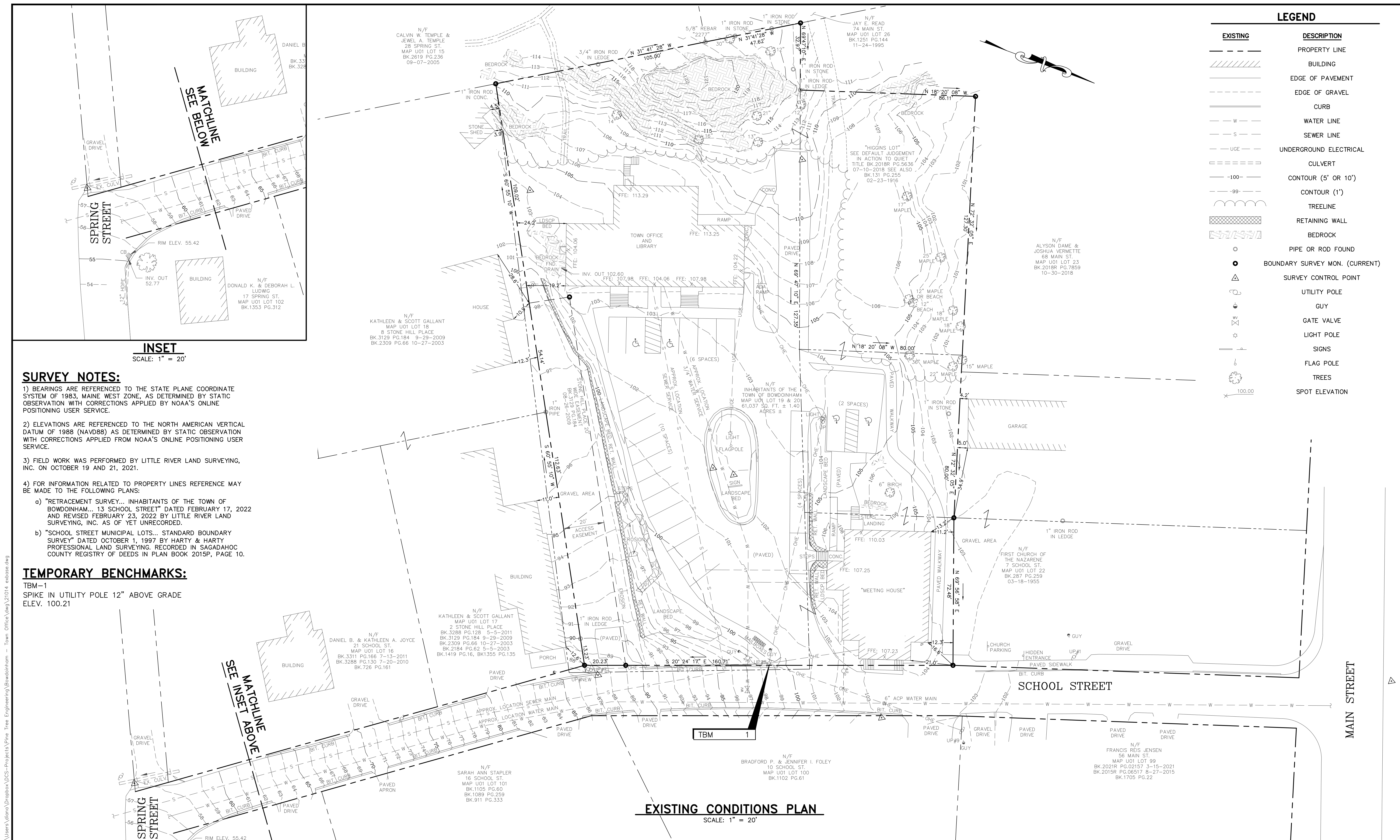

LEGEND	
EXISTING	DESCRIPTION
	PROPERTY LINE
	BUILDING
	EDGE OF PAVEMENT
	EDGE OF GRAVEL
	CURB
	WATER LINE
	SEWER LINE
	UNDERGROUND ELECTRICAL
	CULVERT
	CONTOUR (5' OR 10')
	CONTOUR (1')
	TREELINE
	RETAINING WALL
	BEDROCK
	PIPE OR ROD FOUND
	BOUNDARY SURVEY MON. (CURRENT)
	SURVEY CONTROL POINT
	UTILITY POLE
	GUY
	GATE VALVE
	LIGHT POLE
	SIGNS
	FLAG POLE
	TREES
	SPOT ELEVATION

- INSET**
SCALE: 1" = 20'
- SURVEY NOTES:**
- 1) BEARINGS ARE REFERENCED TO THE STATE PLANE COORDINATE SYSTEM OF 1983, MAINE WEST ZONE, AS DETERMINED BY STATIC OBSERVATION WITH CORRECTIONS APPLIED BY NOAA'S ONLINE POSITIONING USER SERVICE.
 - 2) ELEVATIONS ARE REFERENCED TO THE NORTH AMERICAN VERTICAL DATUM OF 1988 (NAVD88) AS DETERMINED BY STATIC OBSERVATION WITH CORRECTIONS APPLIED FROM NOAA'S ONLINE POSITIONING USER SERVICE.
 - 3) FIELD WORK WAS PERFORMED BY LITTLE RIVER LAND SURVEYING, INC. ON OCTOBER 19 AND 21, 2021.
 - 4) FOR INFORMATION RELATED TO PROPERTY LINES REFERENCE MAY BE MADE TO THE FOLLOWING PLANS:
 - a) "RETRACEMENT SURVEY... INHABITANTS OF THE TOWN OF BOWDOINHAM... 13 SCHOOL STREET" DATED FEBRUARY 17, 2022 AND REVISED FEBRUARY 23, 2022 BY LITTLE RIVER LAND SURVEYING, INC. AS OF YET UNRECORDED.
 - b) "SCHOOL STREET MUNICIPAL LOTS... STANDARD BOUNDARY SURVEY" DATED OCTOBER 1, 1997 BY HARTY & HARTY PROFESSIONAL LAND SURVEYING, RECORDED IN SAGADAHOC COUNTY REGISTRY OF DEEDS IN PLAN BOOK 2015P, PAGE 10.

TEMPORARY BENCHMARKS:
TBM-1
SPIKE IN UTILITY POLE 12" ABOVE GRADE
ELEV. 100.21

EXISTING CONDITIONS PLAN
SCALE: 1" = 20'

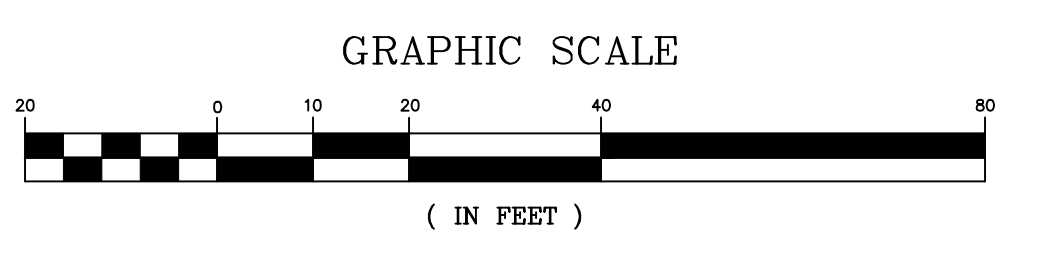

REV	DATE	STATUS	BY	CHKD	APPD
0	3/17/2022	ISSUED FOR BIDDING	DB	JRP	RLP

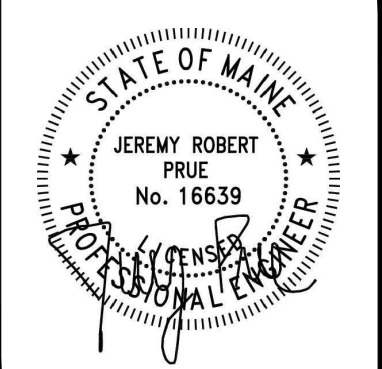

DESIGNED BY: JRP
DRAWN BY: JRP/DB
CHECKED BY: RLP
APPROVED BY: RLP
DATE: 3/17/2022

Pine Tree Engineering
Civil/Environmental Engineering + Surveying
53 Front Street
Bath, Maine 04530
Tel: (207) 443-1508
Fax: (207) 442-7029

CLIENT
TOWN OF BOWDOINHAM
13 SCHOOL STREET
BOWDOINHAM, MAINE 04008

PROJECT
TOWN OFFICE RENOVATIONS
SITWORK
TITLE
EXISTING CONDITIONS PLAN

SCALE	AS SHOWN
PROJECT NO.	21014
DRAWING NO.	21014 exbase
SHT.	2 of 7
REV.	0

C:\Users\dlano\Dropbox\DCS-Projects\Pine Tree Engineering\Bowdoinhom - Town Office\dwg\21014 exbase.dwg 03/17/22 7:15am

C:\Users\jdiana\Dropbox\DCS-Projects\Pine Tree Engineering\Bowdoinham - Town Office\dwg\21014 exbase.dwg 03/17/22 7:15am

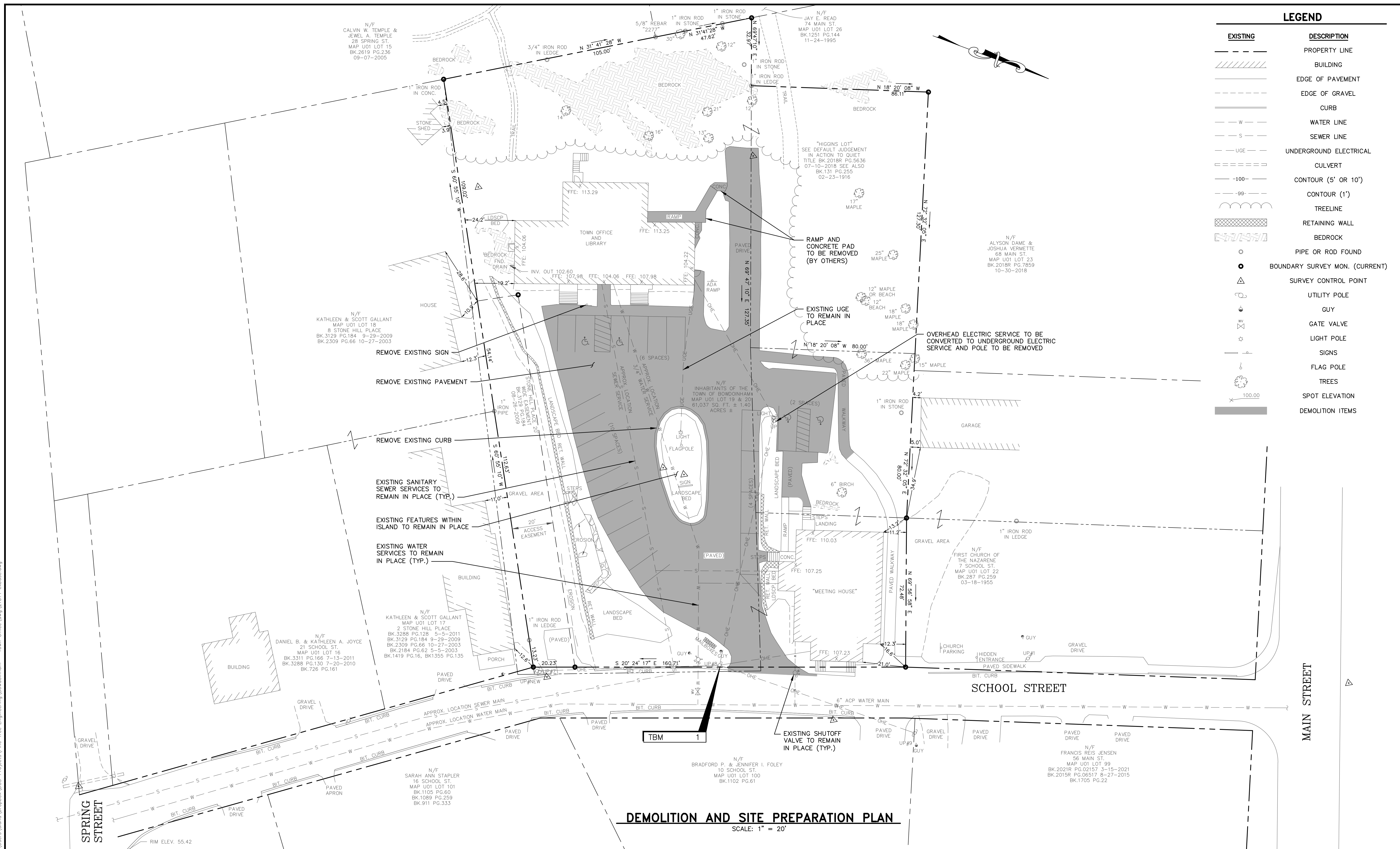

LEGEND	
EXISTING	DESCRIPTION
---	PROPERTY LINE
	BUILDING
---	EDGE OF PAVEMENT
---	EDGE OF GRAVEL
---	CURB
---	WATER LINE
---	SEWER LINE
---	UNDERGROUND ELECTRICAL
---	CULVERT
---	CONTOUR (5' OR 10')
---	CONTOUR (1')
---	TREELINE
---	RETAINING WALL
---	BEDROCK
○	PIPE OR ROD FOUND
●	BOUNDARY SURVEY MON. (CURRENT)
△	SURVEY CONTROL POINT
○	UTILITY POLE
○	GUY
○	GATE VALVE
○	LIGHT POLE
○	SIGNS
○	FLAG POLE
○	TREES
○	SPOT ELEVATION
○	DEMOLITION ITEMS

DEMOLITION AND SITE PREPARATION PLAN
SCALE: 1" = 20'

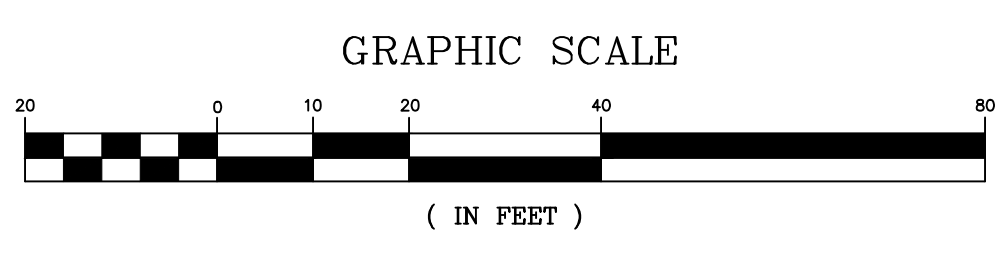

REV	DATE	STATUS	BY	CHKD	APPD
0	3/17/2022	ISSUED FOR BIDDING	DB	JRP	RLP

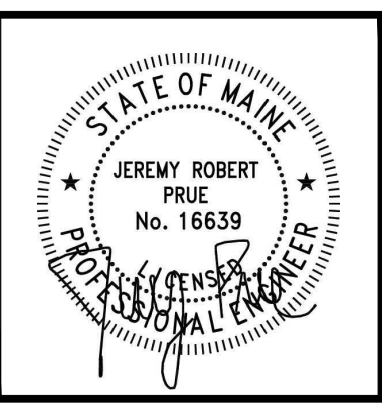

DESIGNED BY:	JRP
DRAWN BY:	JRP/DB
CHECKED BY:	RLP
APPROVED BY:	RLP
DATE:	3/17/2022

Pine Tree Engineering
Civil/Environmental Engineering + Surveying
53 Front Street
Bath, Maine 04530
Tel: (207) 443-1508
Fax: (207) 442-7029

CLIENT
TOWN OF BOWDOINHAM
13 SCHOOL STREET
BOWDOINHAM, MAINE 04008

PROJECT
TOWN OFFICE RENOVATIONS
SITWORK
TITLE
DEMOLITION AND
SITE PREPARATION PLAN

SCALE	AS SHOWN
PROJECT NO.	21014
DRAWING NO.	21014 exbase
SHT.	3 of 7
REV.	0

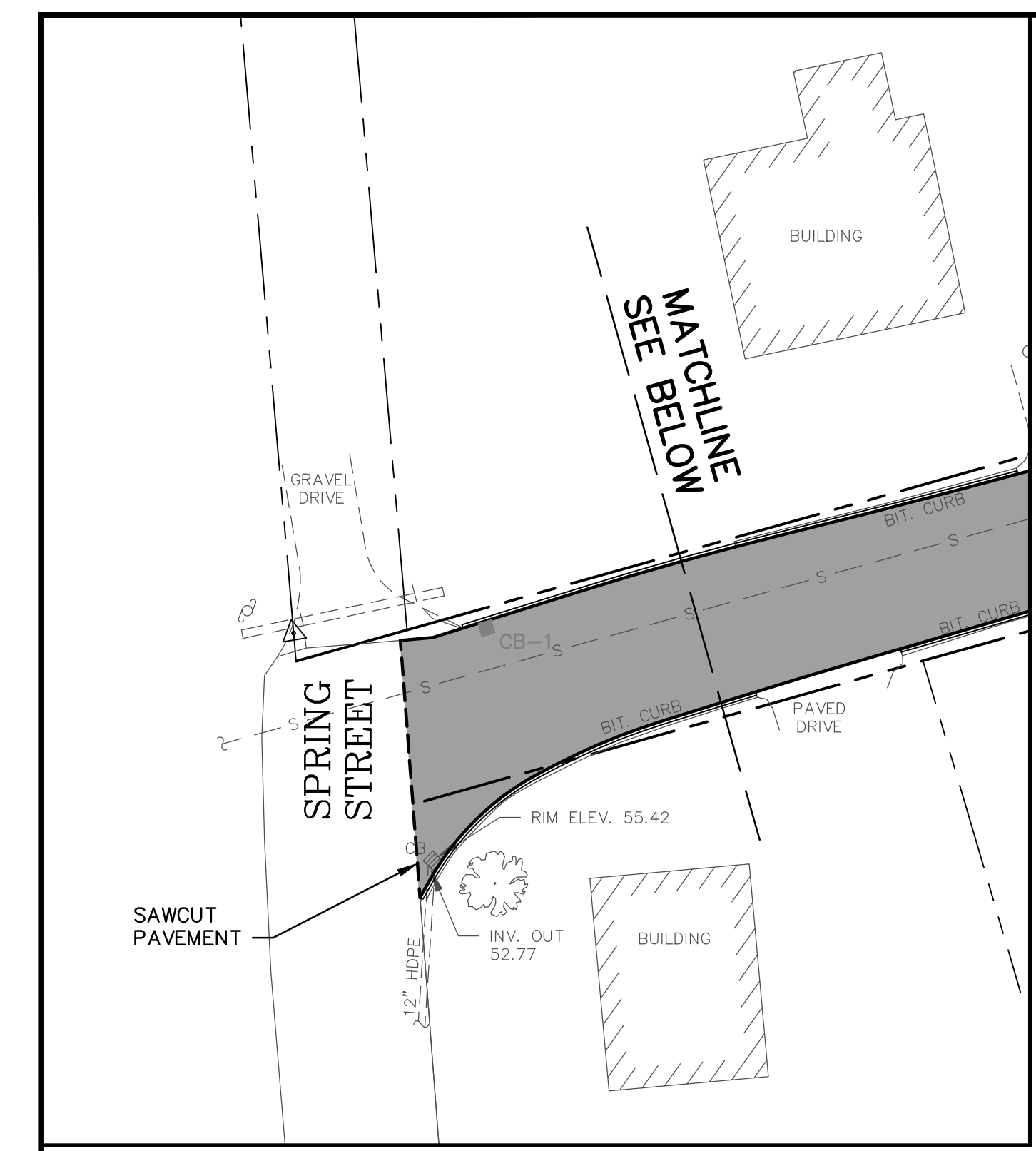

INSET
SCALE: 1" = 20'

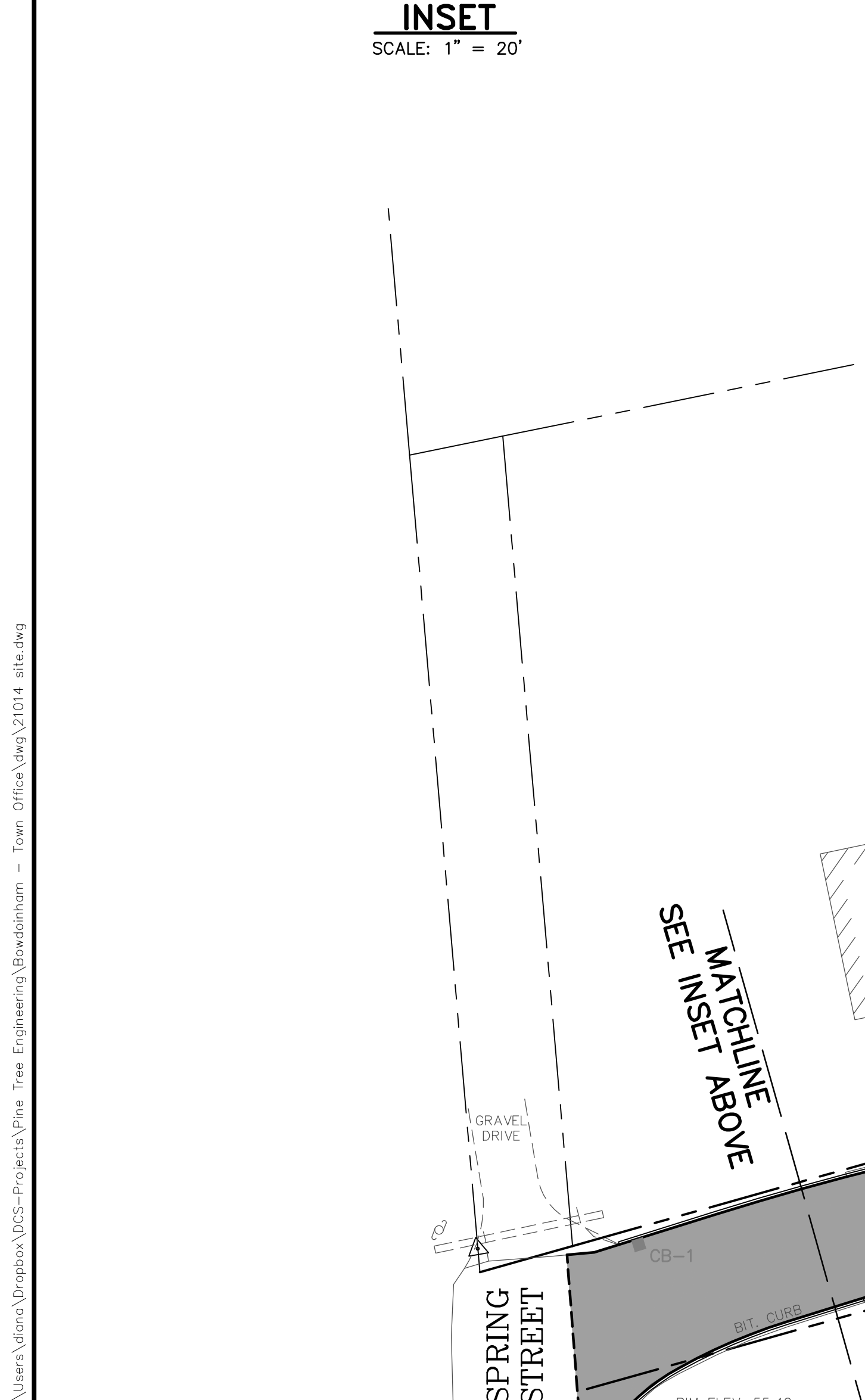

PROPOSED SITE PLAN
SCALE: 1" = 20'

EXISTING	DESCRIPTION	PROPOSED
---	PROPERTY LINE	---
---	SETBACK LINE	---
▨	BUILDING	▨
▨	EDGE OF PAVEMENT	▨
▨	EDGE OF GRAVEL	▨
---	CURB	---
~	TREELINE	~
---	FENCE	---
▨	RETAINING WALL	▨
▨	BEDROCK	▨
△	SURVEY CONTROL POINT	△
○	PIPE OR ROD FOUND	○
●	BOUNDARY SURVEY MON. (CURRENT)	●
○	UTILITY POLE	○
○	GUY	○
○	LIGHT POLE	○
○	SIGNS	○
○	FLAG POLE	○
○	TREES	○
---	SAWCUT	---
○	DRAIN MANHOLE	○
○	CATCH BASIN	○
○	SEPTIC TANK ACCESS COVER	○
▨	OVERLAY	▨

C:\Users\jrobert\Dropbox\DCS-Projects\Pine Tree Engineering\Bowdoinham - Town Office\dwg\21014 site.dwg 03/17/22 7:15am

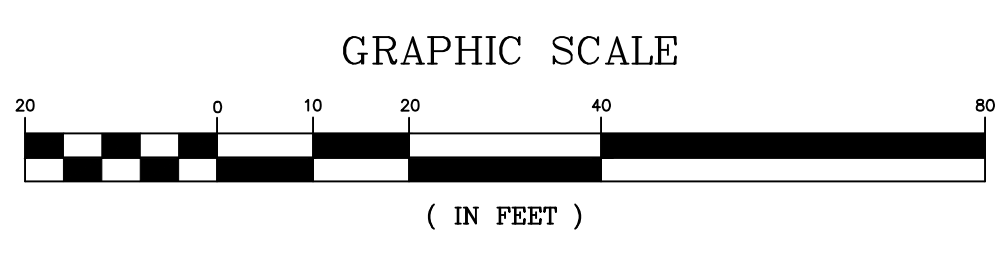

REV	DATE	STATUS	BY	CHKD	APPD
0	3/17/2022	ISSUED FOR BIDDING	DB	JRP	RLP

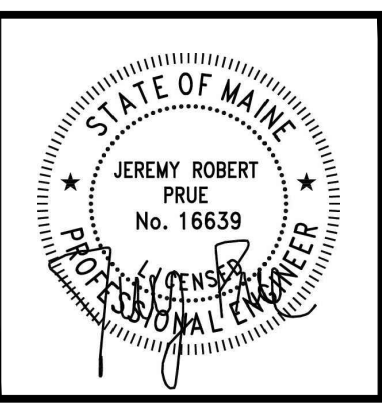

DESIGNED BY: JRP
 DRAWN BY: JRP/DB
 CHECKED BY: RLP
 APPROVED BY: RLP
 DATE: 3/17/2022

Pine Tree Engineering
 Civil/Environmental Engineering + Surveying
 53 Front Street
 Bath, Maine 04530
 Tel: (207) 443-1508
 Fax: (207) 442-7029

CLIENT
TOWN OF BOWDOINHAM
 13 SCHOOL STREET
 BOWDOINHAM, MAINE 04008

PROJECT
TOWN OFFICE RENOVATIONS
SITWORK
 TITLE
PROPOSED SITE PLAN

SCALE	AS SHOWN
PROJECT NO.	21014
DRAWING NO.	21014 site
SHT.	4 of 7
REV.	0

NOTE:
CONCRETE PADS TO BE 6" THICK
WITH 6" WELDED WIRE MESH.

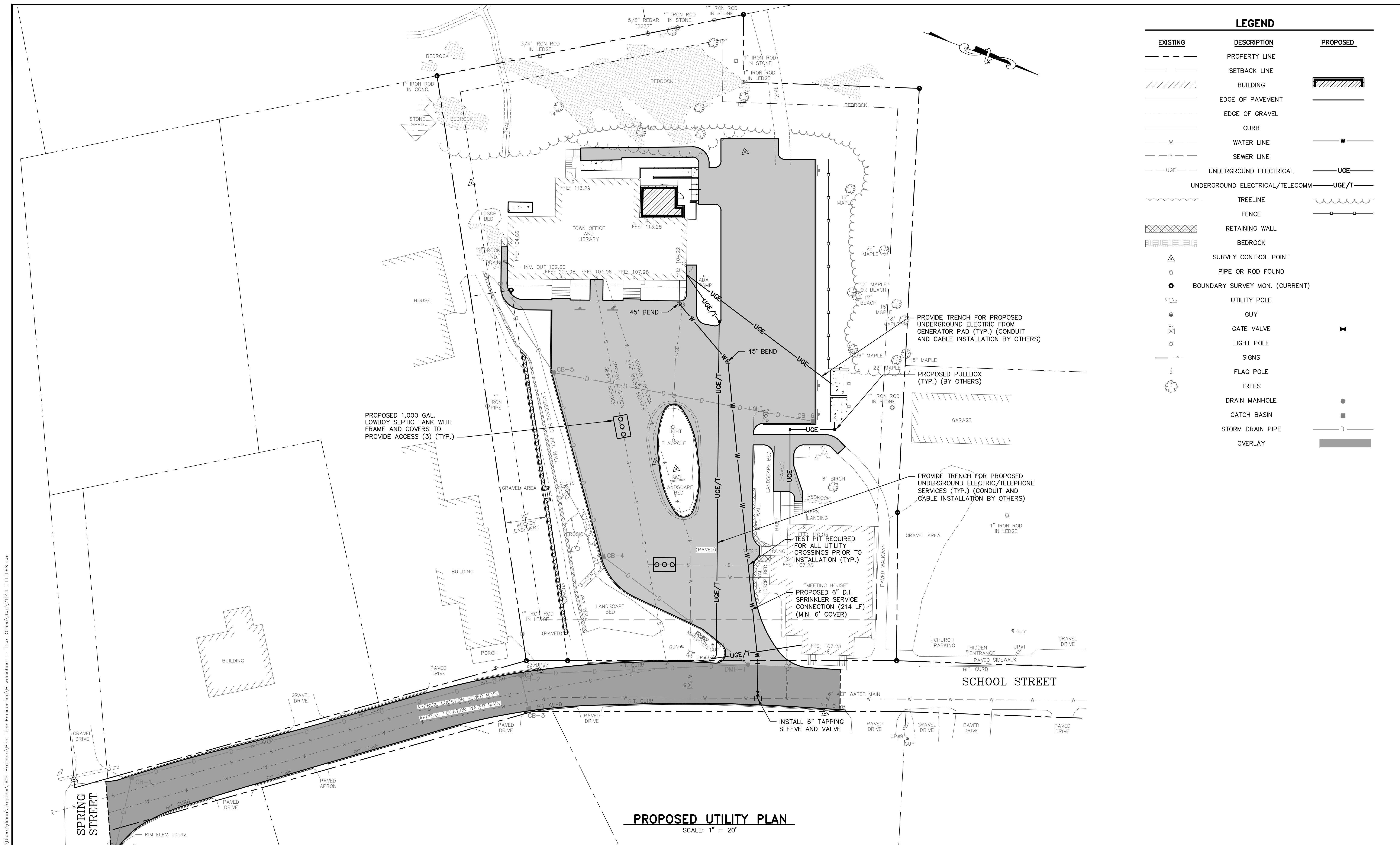

LEGEND		
EXISTING	DESCRIPTION	PROPOSED
---	PROPERTY LINE	---
---	SETBACK LINE	---
	BUILDING	
---	EDGE OF PAVEMENT	---
---	EDGE OF GRAVEL	---
---	CURB	---
W	WATER LINE	W
S	SEWER LINE	S
UGE	UNDERGROUND ELECTRICAL	UGE
UGE/T	UNDERGROUND ELECTRICAL/TELECOMM	UGE/T
~~~~~	TREELINE	~~~~~
---	FENCE	---
XXXXX	RETAINING WALL	XXXXX
	BEDROCK	
△	SURVEY CONTROL POINT	△
○	PIPE OR ROD FOUND	○
●	BOUNDARY SURVEY MON. (CURRENT)	●
○	UTILITY POLE	○
○	GUY	○
○	GATE VALVE	○
○	LIGHT POLE	○
○	SIGNS	○
○	FLAG POLE	○
○	TREES	○
○	DRAIN MANHOLE	○
○	CATCH BASIN	○
---	STORM DRAIN PIPE	---
---	OVERLAY	---

**PROPOSED UTILITY PLAN**  
SCALE: 1" = 20'

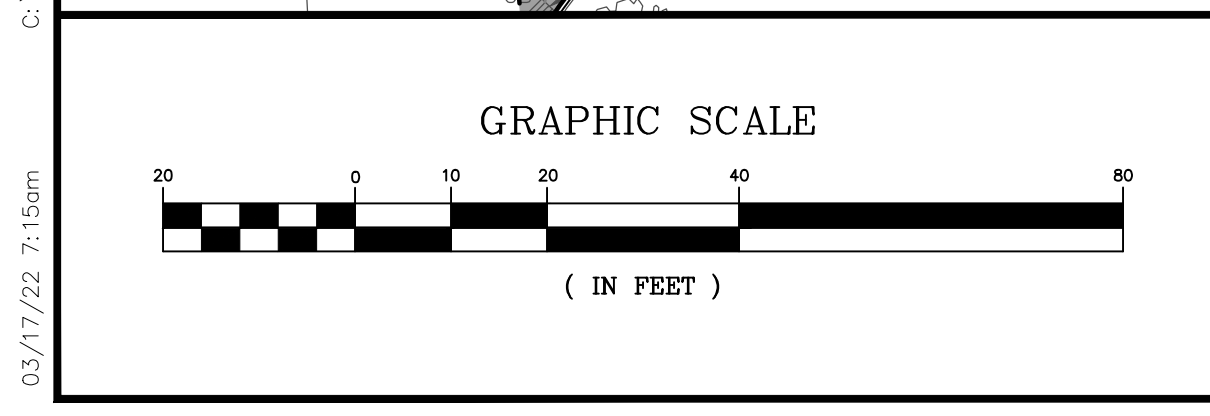

REV	DATE	STATUS	BY	CHKD	APPD
0	3/17/2022	ISSUED FOR BIDDING	DB	JRP	RLP

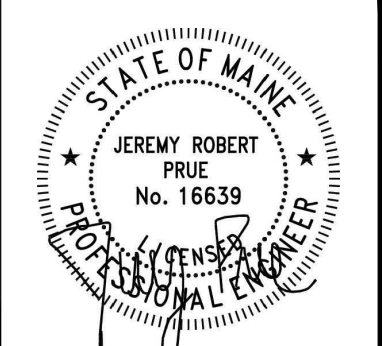

DESIGNED BY: JRP  
 DRAWN BY: JRP/DB  
 CHECKED BY: RLP  
 APPROVED BY: RLP  
 DATE: 3/17/2022

**Pine Tree Engineering**  
 Civil/Environmental Engineering + Surveying  
 53 Front Street  
 Bath, Maine 04530  
 Tel: (207) 443-1508  
 Fax: (207) 442-7029

CLIENT  
**TOWN OF BOWDOINHAM**  
 13 SCHOOL STREET  
 BOWDOINHAM, MAINE 04008

PROJECT  
**TOWN OFFICE RENOVATIONS  
 SITWORK**  
 TITLE  
**PROPOSED UTILITY PLAN**

SCALE  
 AS SHOWN  
 PROJECT NO.  
 21014  
 DRAWING NO.  
 21014 UTILITIES  
 SHT. **5** of 7 REV. 0

C:\Users\jprue\Documents\Projects\Pine Tree Engineering\Bowdoinham - Town Office\Uwg\21014 UTILITIES.dwg 03/17/22 7:15am

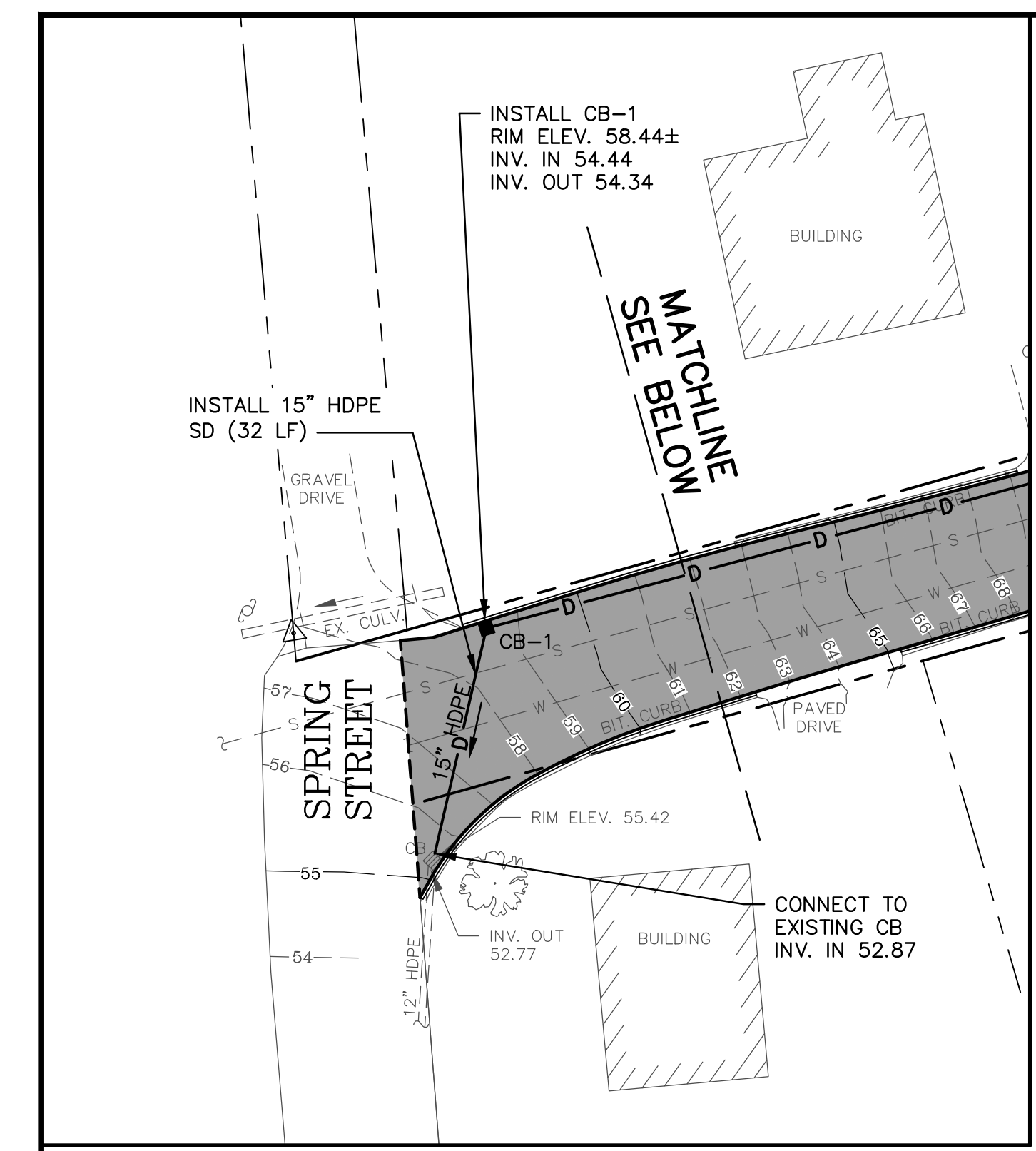

**INSET**  
SCALE: 1" = 20'

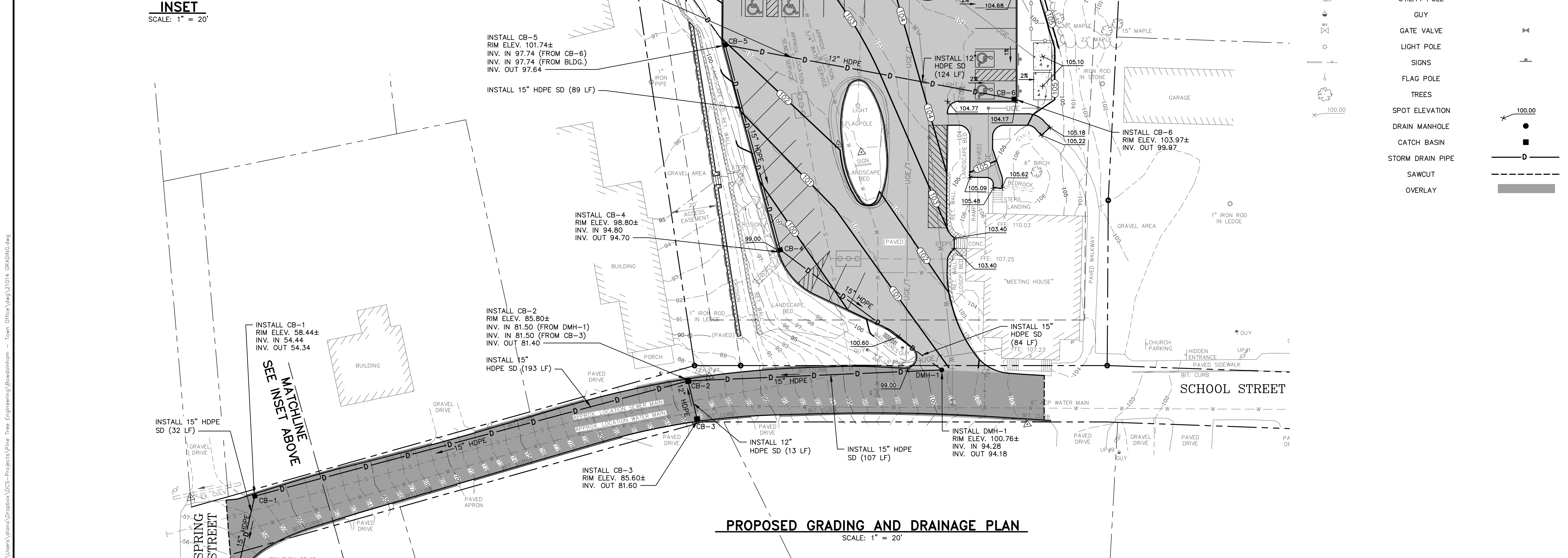

LEGEND		
EXISTING	DESCRIPTION	PROPOSED
---	PROPERTY LINE	---
---	SETBACK LINE	---
▨	BUILDING	▨
---	EDGE OF PAVEMENT	---
---	EDGE OF GRAVEL	---
---	CURB	---
---	WATER LINE	W
---	SEWER LINE	S
---	UNDERGROUND ELECTRICAL	UGE
---	UNDERGROUND ELECTRICAL/TELECOMM	UGE/T
---	CULVERT	---
---	CONTOUR (5' OR 10')	100
---	CONTOUR (1')	99
---	TREELINE	---
---	FENCE	---
---	RETAINING WALL	---
---	BEDROCK	---
△	SURVEY CONTROL POINT	△
○	PIPE OR ROD FOUND	○
○	BOUNDARY SURVEY MON. (CURRENT)	○
○	UTILITY POLE	○
○	GUY	○
○	GATE VALVE	○
○	LIGHT POLE	○
○	SIGNS	○
○	FLAG POLE	○
○	TREES	○
○	SPOT ELEVATION	100.00
○	DRAIN MANHOLE	○
○	CATCH BASIN	○
---	STORM DRAIN PIPE	D
---	SAWCUT	---
---	OVERLAY	---

C:\Users\jrlano\Dropbox\DCS-Projects\Pine Tree Engineering\Bowdoinhom - Town Office\dwg\21014 GRADING.dwg 03/17/22 7:15am

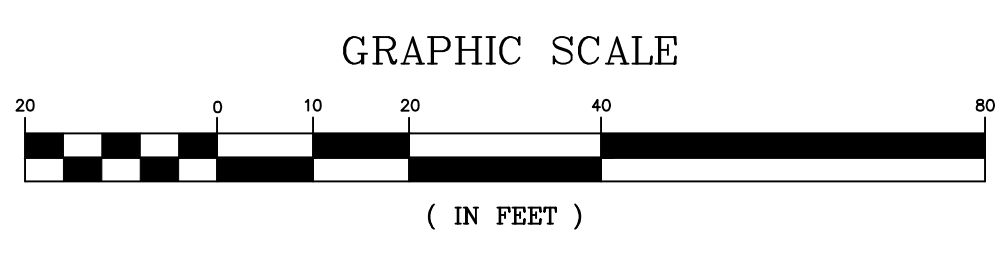

REV	DATE	STATUS	BY	CHKD	APPD
0	3/17/2022	ISSUED FOR BIDDING	DB	JRP	RLP

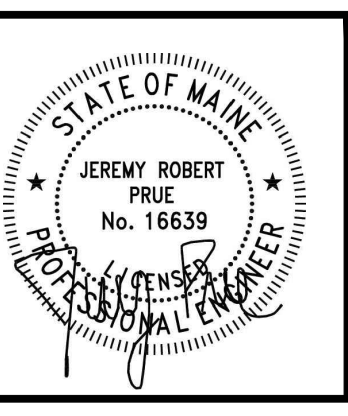

DESIGNED BY: JRP  
DRAWN BY: JRP/DB  
CHECKED BY: RLP  
APPROVED BY: RLP  
DATE: 3/17/2022

**Pine Tree Engineering**  
Civil/Environmental Engineering + Surveying  
53 Front Street  
Bath, Maine 04530  
Tel: (207) 443-1508  
Fax: (207) 442-7029

CLIENT  
**TOWN OF BOWDOINHAM**  
13 SCHOOL STREET  
BOWDOINHAM, MAINE 04008

PROJECT  
**TOWN OFFICE RENOVATIONS**  
SITWORK  
TITLE  
**PROPOSED GRADING AND**  
**DRAINAGE PLAN**

SCALE  
AS SHOWN  
PROJECT NO.  
21014  
DRAWING NO.  
21014 GRADING  
SHT. **6** of 7 REV.  
0

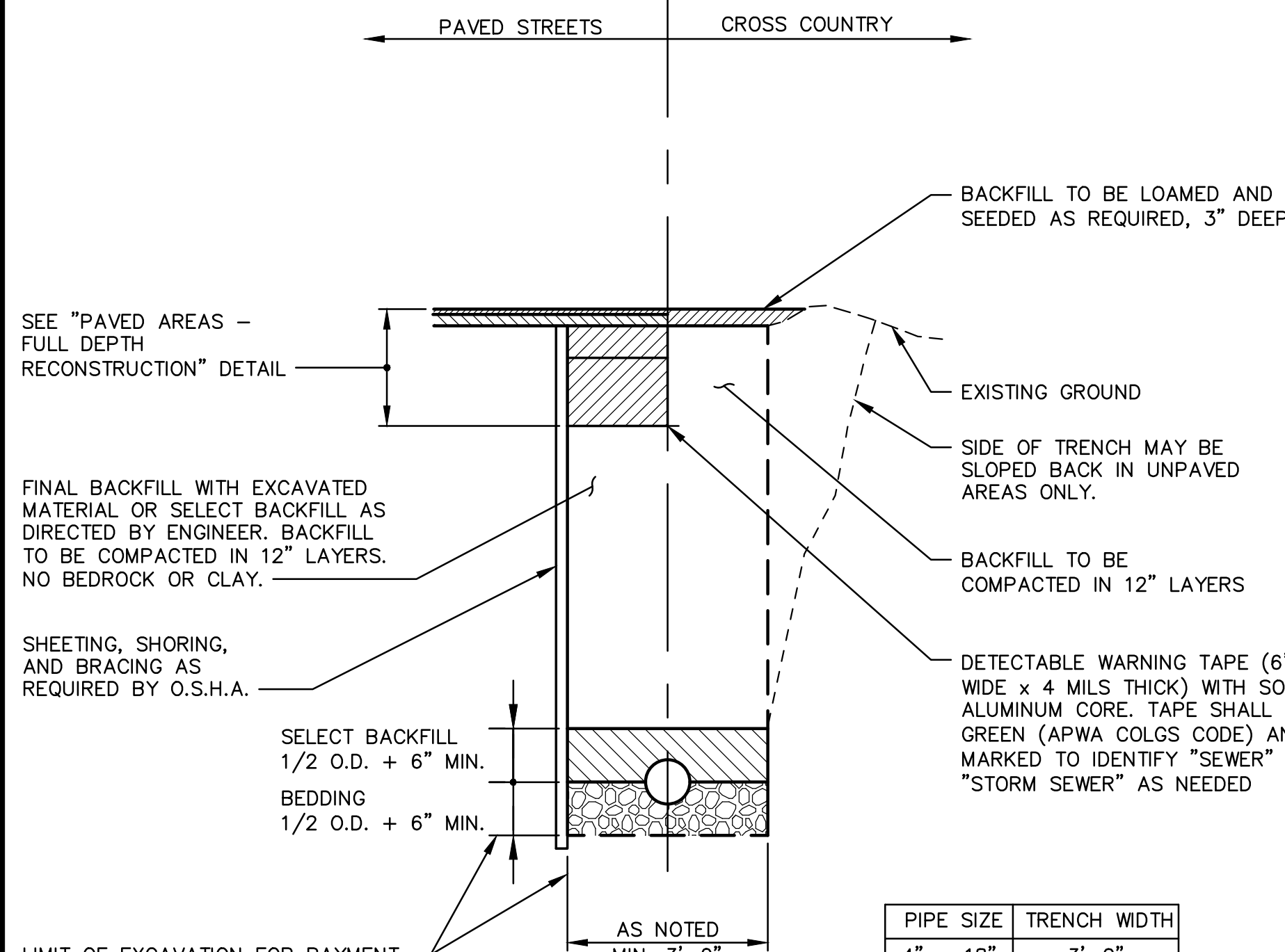

**PVC/HDPE PIPE TYPICAL TRENCH DETAIL**  
SCALE: 1/2" = 1'-0"

PIPE SIZE	TRENCH WIDTH
4" - 18"	3'-0"
24" - 30"	4'-0"
36"	5'-0"

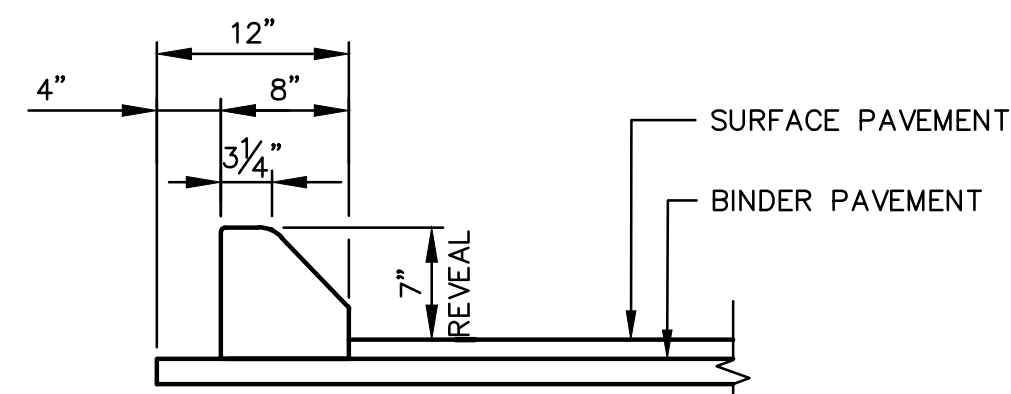

**SLIPFORM CONCRETE CURB DETAIL**  
SCALE: 1" = 1'-0"

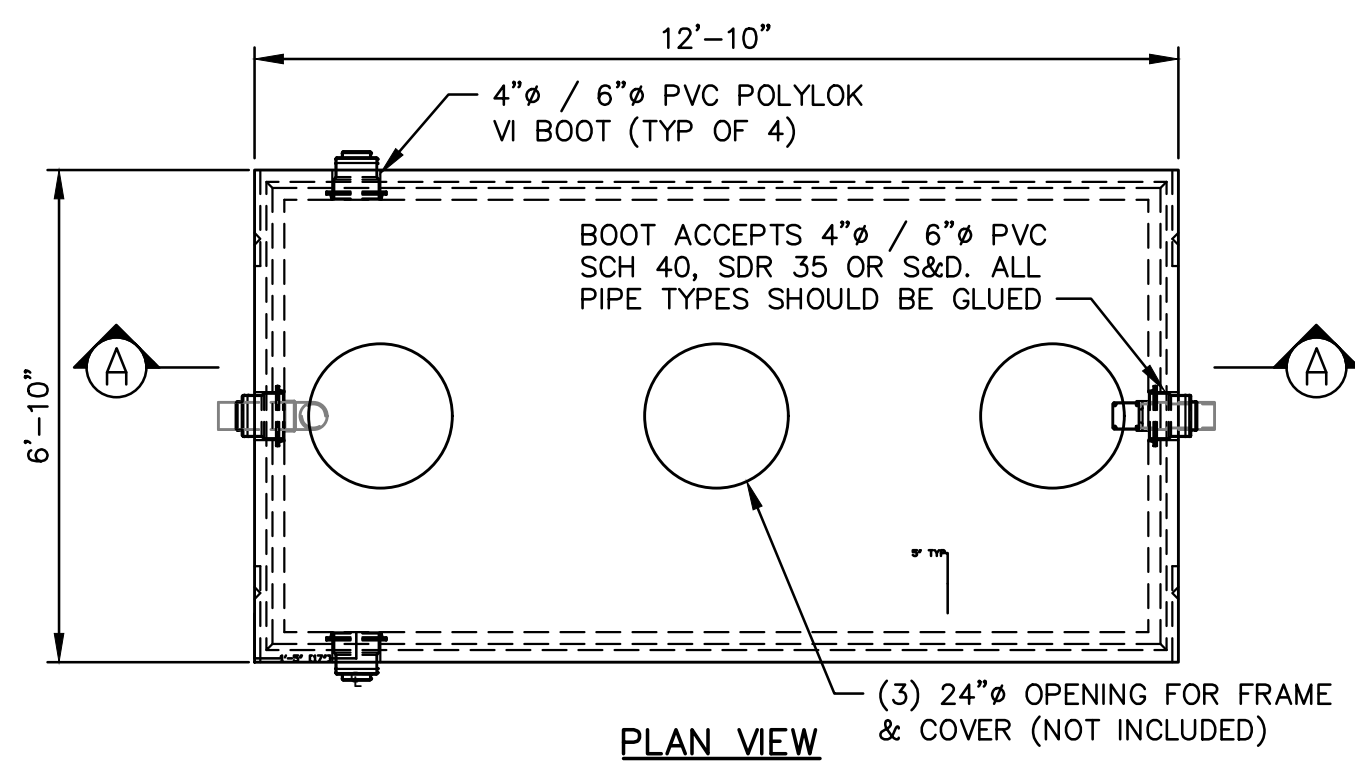

**PAVED AREAS - FULL DEPTH RECONSTRUCTION**  
SCALE: 1" = 1'-0"

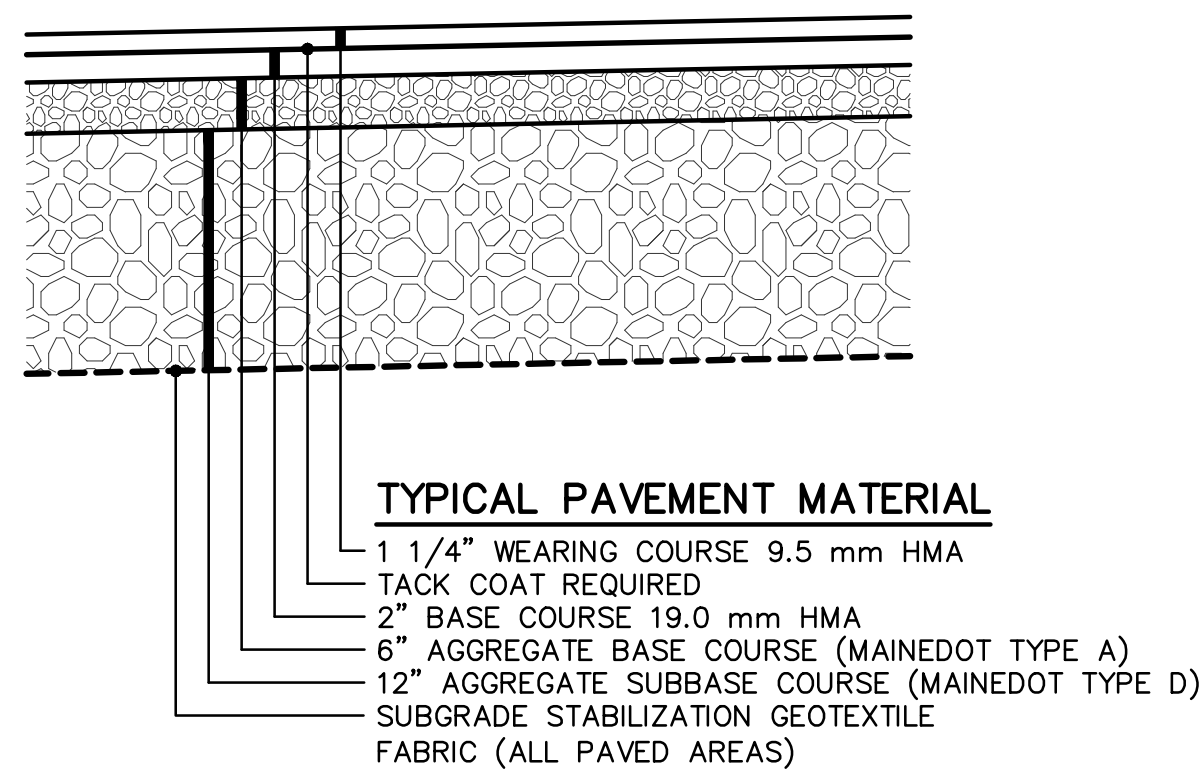

**TYPICAL SIDEWALK SECTION**  
SCALE: 1" = 2'-0"

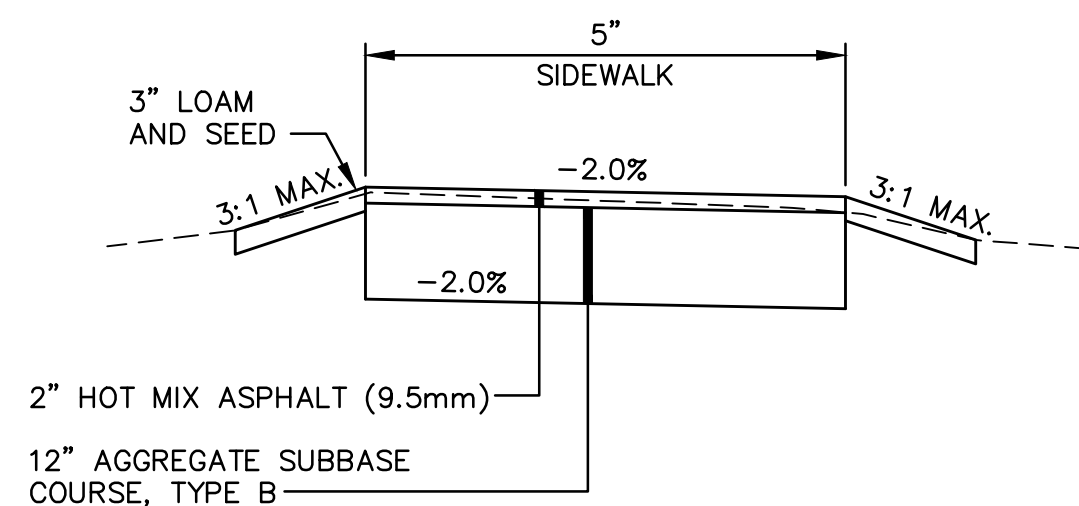

**ACCESSIBLE PARKING SPACE MARKING DETAIL**  
NOT TO SCALE

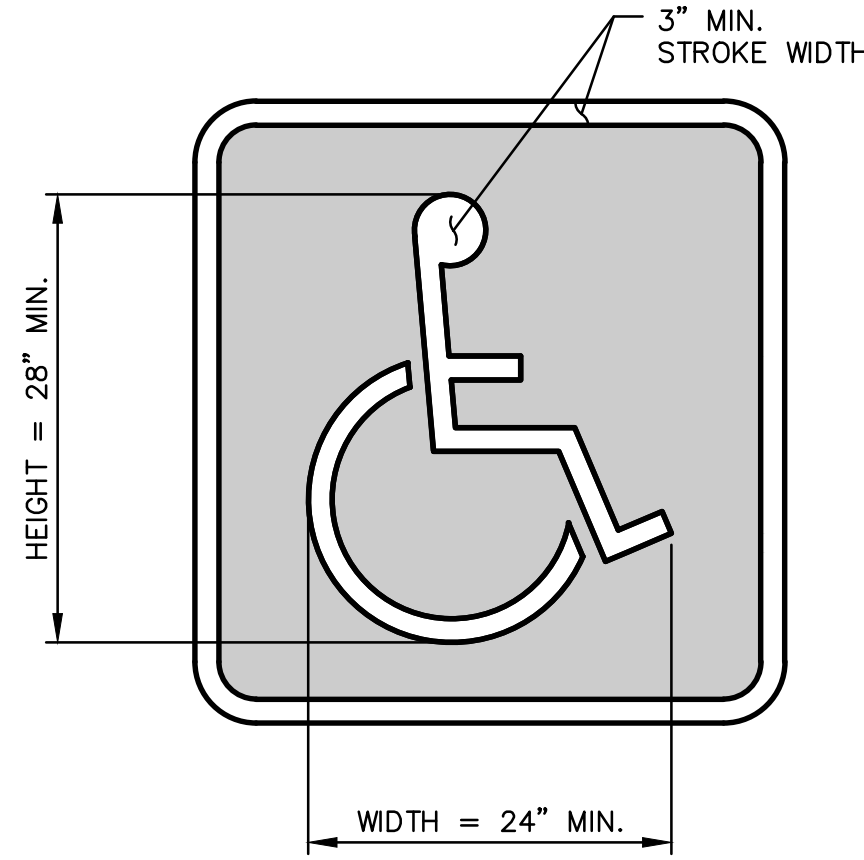

**ACCESSIBLE PARKING SIGN DETAIL**  
NOT TO SCALE

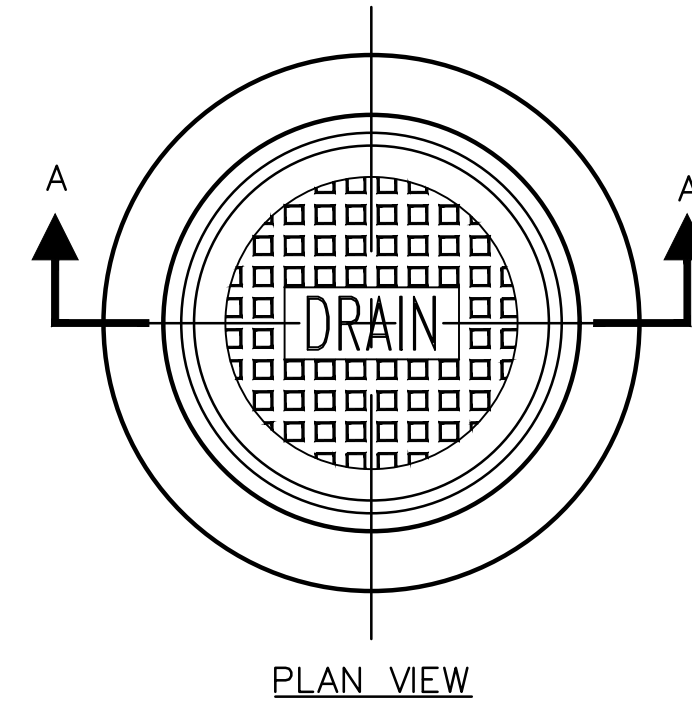
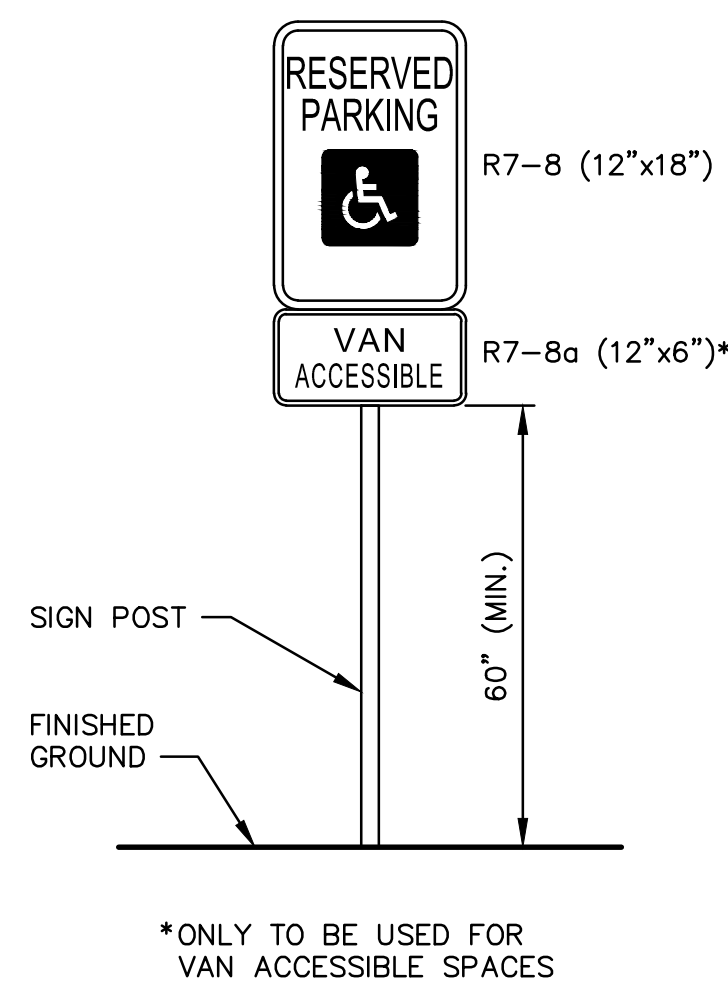

**DRAIN MANHOLE FRAME & COVER**  
NOT TO SCALE

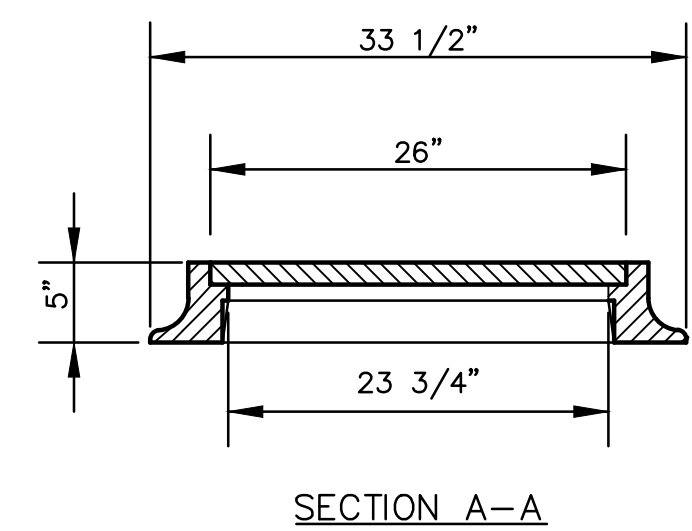

**STORM DRAIN MANHOLE OR CATCH BASIN - ECCENTRIC**  
SCALE: 1/2" = 1'-0"

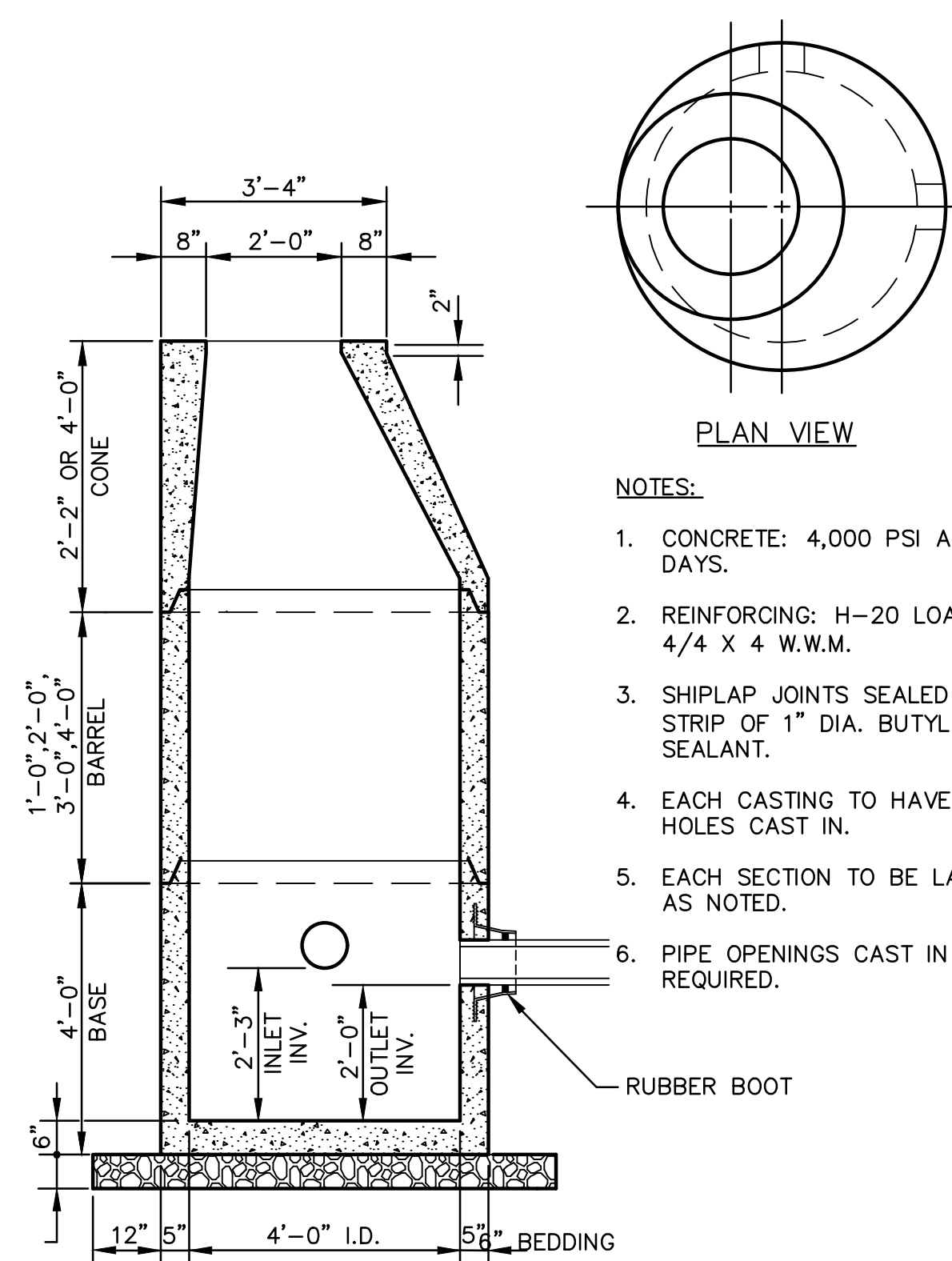

SECTION VIEW

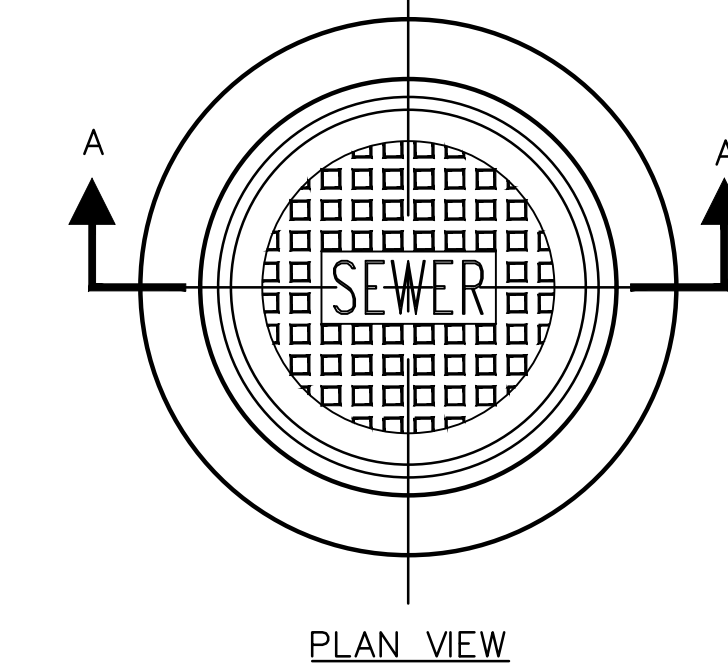

**SEWER MANHOLE FRAME & COVER**  
NOT TO SCALE

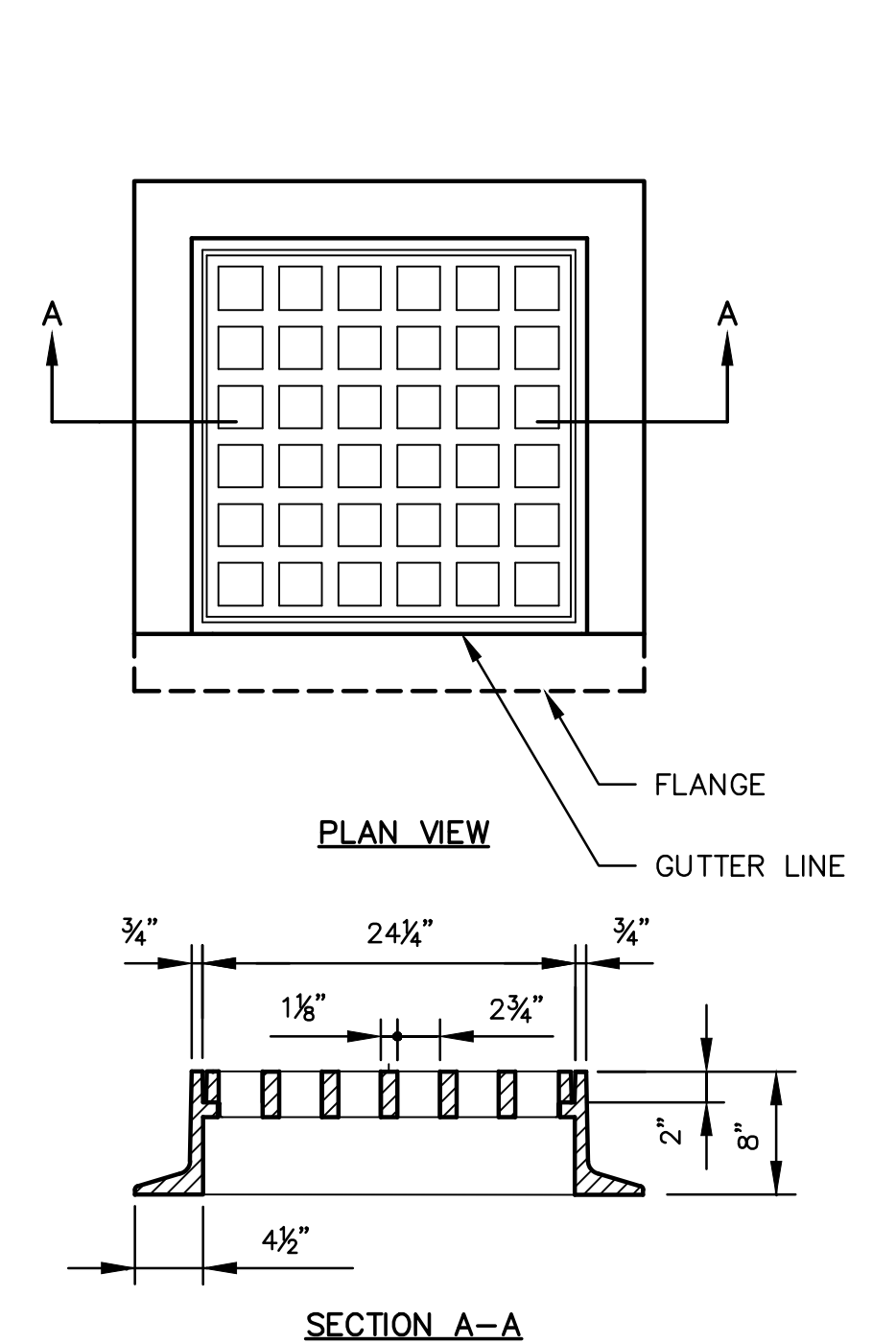
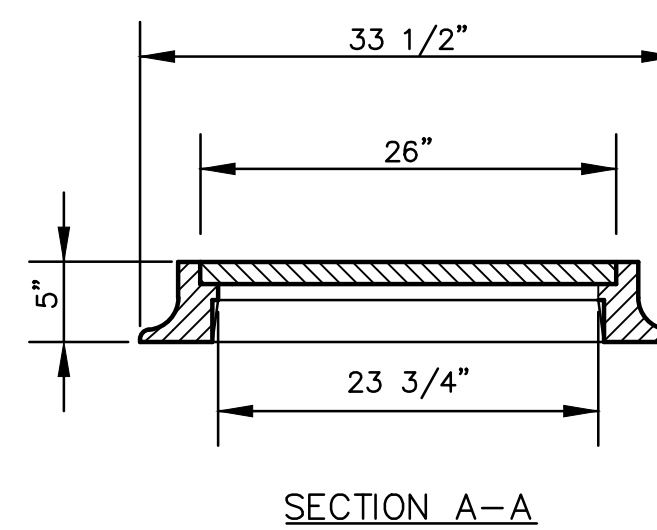

**CATCH BASIN FRAME AND GRATE TYPE "A" & "B"**  
SCALE: 1" = 1'-0"

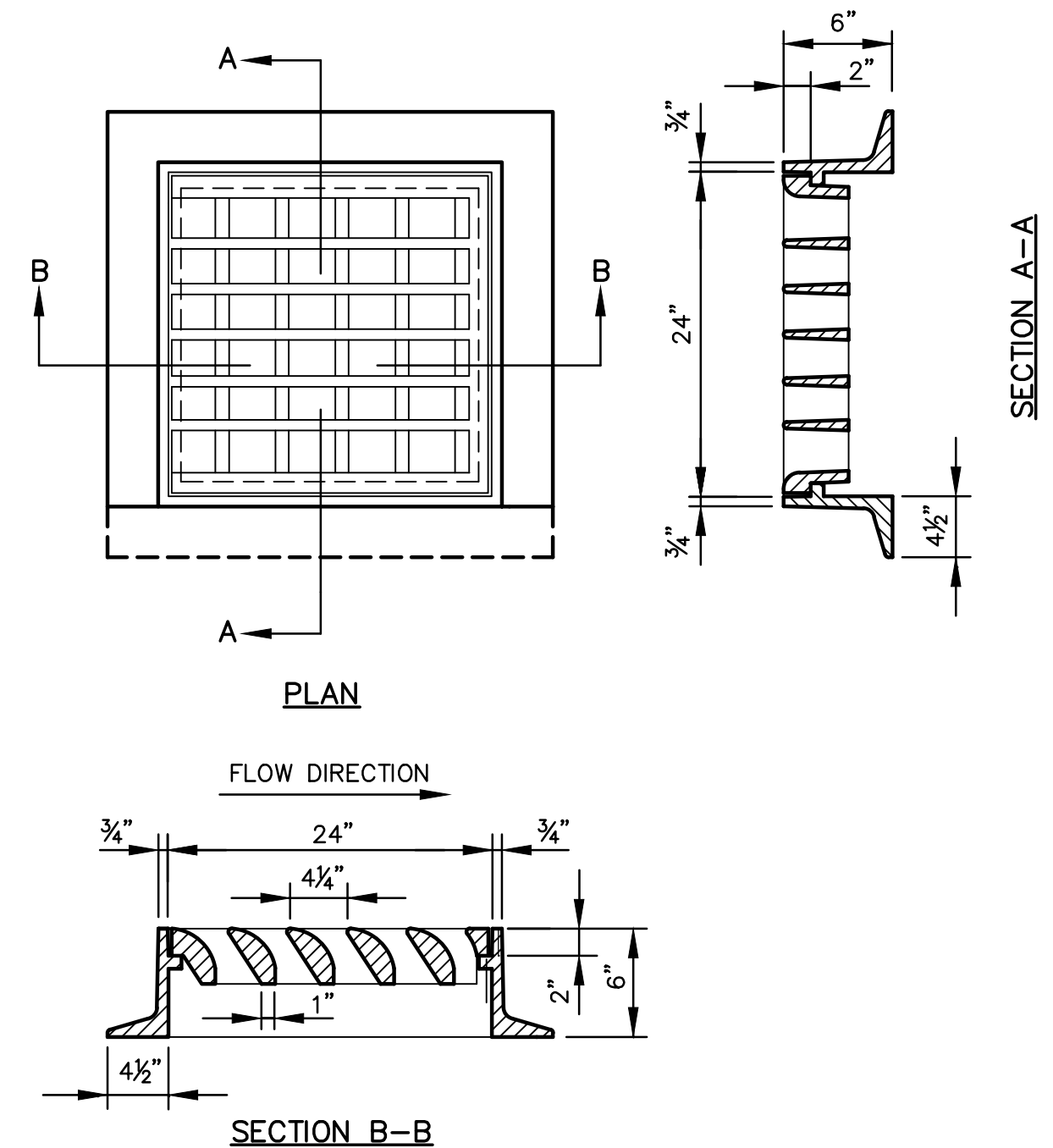

**CATCH BASIN FRAME WITH CASCADE TYPE GRATE**  
SCALE: 1" = 1'-0"

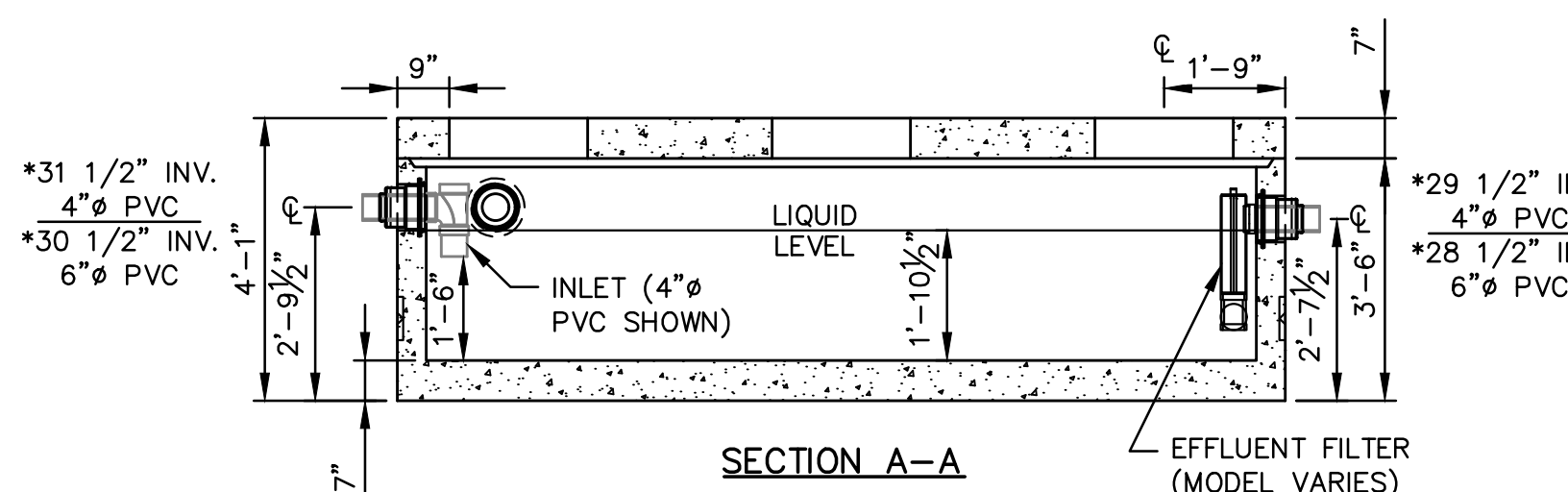

**1,000 GALLON LOWBOY SEPTIC TANK DETAIL**  
SCALE: 3/8" = 1'-0"

- *DIMENSION IS TAKEN FROM BOTTOM OF TANK
- MANUFACTURING NOTES:**
- 1.1. CONCRETE COMPRESSIVE STRENGTH: 5000PSI @ 28 DAYS
  - 1.2. AIR ENTRAINMENT: 4-6%
  - 1.3. GRADE 60 REINFORCEMENT
  - 1.4. TANKS SHOULD BE PUMPED EVERY 3-5 YEARS, DEPENDING ON USE
  - 1.5. NEVER USE SEPTIC CLEANING AGENTS
  - 1.6. DESIGNED FOR H2O LOAD RATING
  - 1.7. REQUIRES GRADE RINGS TO GRADE & H2O FRAMES & COVERS
  - 1.8. ALL TANK PENETRATIONS ARE INTEGRALLY CAST
  - 1.9. ALL JOINTS SEALED W/ BUTYL RUBBER JOINT SEALANT
- PHYSICAL SPECIFICATIONS:**
- COVER WEIGHT: 6,995 LBS  
 TANK WEIGHT: 14,305 LBS  
 TOTAL WEIGHT: 21,300 LBS  
 AVAILABLE CAPACITY: 1,505 GAL (MAX)  
 WORKING CAPACITY: 1,011 GAL (4" PVC) 966 GAL (6" PVC)

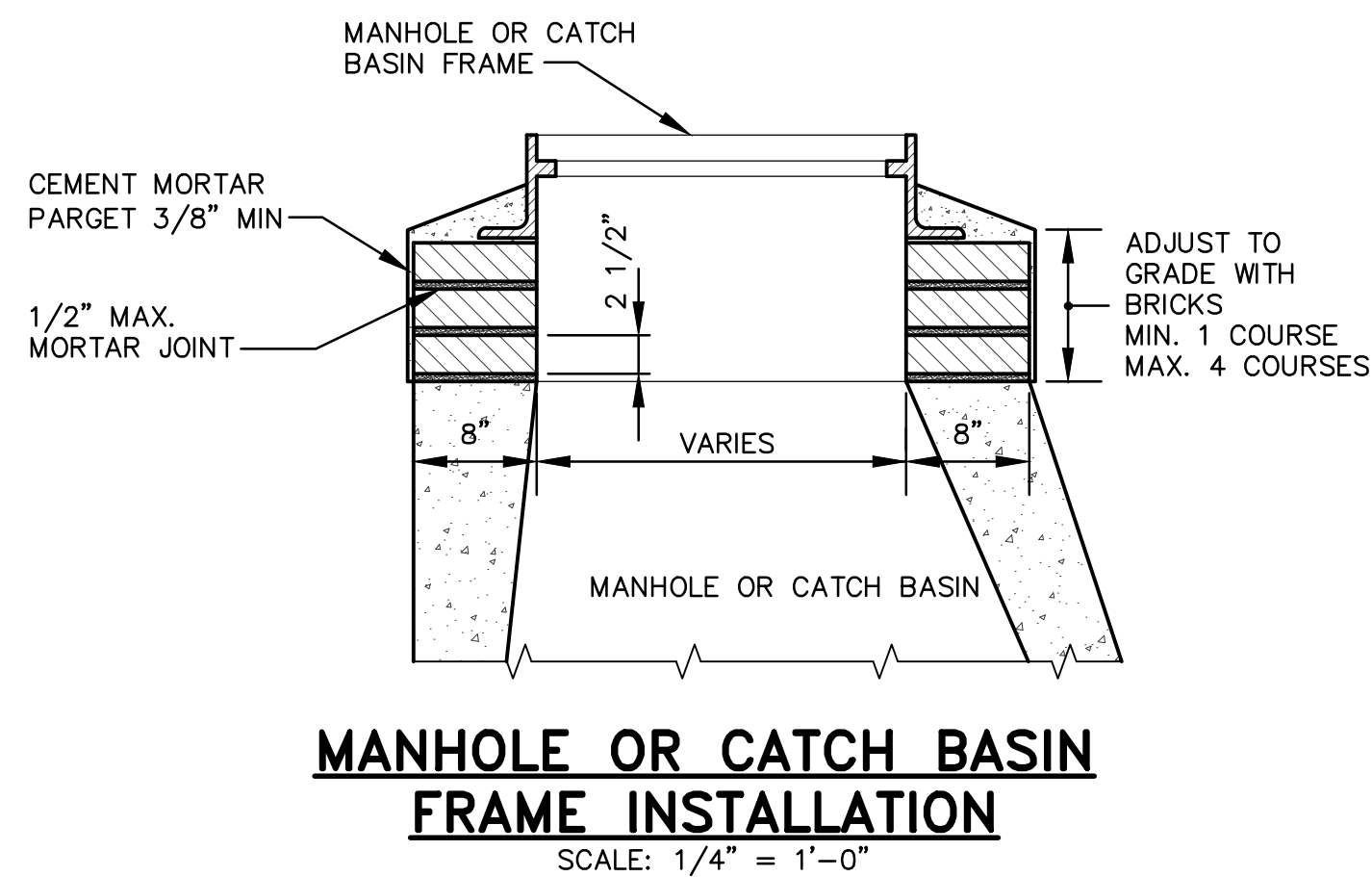

**MANHOLE OR CATCH BASIN FRAME INSTALLATION**  
SCALE: 1/4" = 1'-0"

C:\Users\jdrobinson\Dropbox\DCS-Projects\Pine Tree Engineering\Bowdoinham - Town Office\dwg\21014 DETAILS.dwg 03/17/22 7:16am

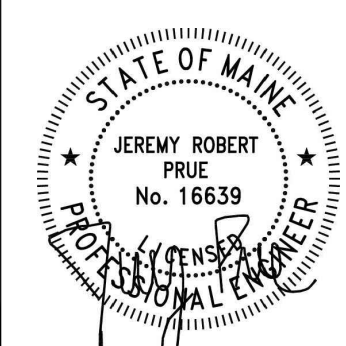

DESIGNED BY: JRP  
 DRAWN BY: JRP/DB  
 CHECKED BY: RLP  
 APPROVED BY: RLP  
 DATE: 3/17/2022

**Pine Tree Engineering**  
 53 Front Street  
 Bath, Maine 04530  
 Tel: (207) 443-1508  
 Fax: (207) 442-7029  
 Civil/Environmental Engineering + Surveying

CLIENT  
**TOWN OF BOWDOINHAM**  
 13 SCHOOL STREET  
 BOWDOINHAM, MAINE 04008

PROJECT  
**TOWN OFFICE RENOVATIONS SITEWORK**  
 TITLE  
**DETAILS**

SCALE AS SHOWN  
 PROJECT NO. 21014  
 DRAWING NO. 21014 DETAILS  
 SHT. 7 of 7 REV. 0

REV	DATE	STATUS	BY	CHKD	APPD
0	3/17/2022	ISSUED FOR BIDDING	DB	JRP	RLP